

RCA

Digital Camcorder User's Guide

Changing Entertainment. Again.



CC9360

Important Information

WARNING

To reduce the risk of fire or electric shock, do not expose this product or AC charger to rain or moisture.

WARNING

RISK OF ELECTRIC SHOCK
DO NOT OPEN

To reduce the risk of electric shock, do not remove cover (or back). No user serviceable parts inside. Refer servicing to qualified service personnel.



This symbol indicates "dangerous voltage" inside the product that presents a risk of electric shock or personal injury.



This symbol indicates important instructions accompanying the product.

To reduce risk of injury, charge only rechargeable batteries recommended by the manufacturer for this product. Other types of batteries may burst causing damage and personal injury.

FCC Regulations state that unauthorized changes or modifications to this equipment may void the user's authority to operate it.

Product Registration

Please fill out the product registration card and return it immediately. Returning this card allows us to contact you if needed.

Keep your sales receipt for proof of purchase to obtain warranty parts and service and attach it here. Record the serial number and model numbers located on the bottom of the camcorder.

Model No. _____

Serial No. _____

Purchase Date. _____

Purchased From. _____

Table of Contents

Chapter 1: Connections & Setup

Parts Checklist	6
Buttons and Controls	7
Getting Started	9
Unpack the camcorder and accessories	9
Adjust the hand strap	9
Attach the lens cap	10
Attach the power supply	10
Turn on the camcorder	11
Set the LIGHT switch to AUTO	11
Insert a cassette tape	12
Use the LCD monitor or viewfinder to see what's recording	13
Start recording	14
Play your recording	14
Turn off the camcorder	15
Powering the Camcorder	15
Charging the Battery	15
Battery Level Icon	18
Battery Care and Storage	18
Using the Power Supply	19
Using the Shoulder Strap	20
Setting the Date and Time	21
Setting the Tape Recording Speed	22

Chapter 2: Using the Monitors

Seeing What You Are Recording	24
Using the LCD Monitor	24
Using the Viewfinder	25
On-screen Icons	26
Warning Icons	26
Recording and Playback Icons	27
Other Icons	32

(continued on the next page)

Table of Contents

Chapter 3: Recording

Recording Details	34
Journalistic Shooting	34
Self-Recording	35
Digital and Optical Zooming	35
Using Steady Pix™	37
Using the Video Light	38
Time Code Display	39
Selecting a Snapshot Mode	40
Taking Snapshots	42
Blank Search	43
Recording Tips	44

Chapter 4: Playback

Playback Options	46
Basic Playback	46
Still Playback Mode	48
Shuttle Search	48
Frame-By-Frame Playback	49
Choose your Connection	50
Connecting to a TV (or VCR) with Audio/Video Input Jacks	50
Connecting to a TV (or VCR) with an S-Video Input Jack	51
Playback on a TV (or VCR) with Audio/Video Input Jacks	52
Dubbing to a VCR	53
Dubbing to Another Digital Video Camcorder	54

Chapter 5: Advanced Features

Using the Menus For Advanced Adjustment	56
Menu Definitions	57
Camera Menu	57
Manual Menu	58
System Menu	58
Display Menu	59

Table of Contents

Using the Advanced Features	61
Night Mode	61
Fade/Wipe Effects	62
Program AE With Special Effects	65
Exposure Control	68
Iris Lock	69
Focusing	70
White Balance Adjustment	72
Date/Time Insert	73
Wide Mode	74
Wind Cut	76
Resetting the Camcorder Defaults	76
Chapter 6: Downloading to a PC	
Connecting to a Computer	78
Chapter 7: Other Information	
Troubleshooting	80
Final Notes	83
Power	83
Date/Time Settings	83
Video Recording	84
Tapes	85
Care and Cleaning	86
After Using the Camcorder	86
Cleaning The Camcorder	86
Proper Care and Storage	87
Tape Care and Storage	87
Things to Avoid	88
Traveling Tips	88
Specifications	89
Limited Warranty	91
FCC and Industry Canada Information	95
Optional Accessories	96
Accessories Order Form	99
Index	103

This page intentionally left blank.

Connections & Setup

Chapter Overview:

- Parts Checklist
- Buttons and Controls
- Getting Started
- Powering the Camcorder
- Using the Shoulder Strap
- Setting the Date and Time
- Setting the Tape Recording Speed

Changing Entertainment. Again.



Connections & Setup

Parts Checklist

Make sure the box includes the items shown here:

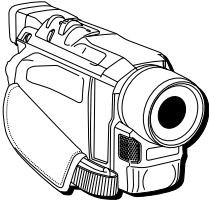

Camcorder

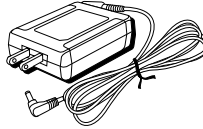

*AC power supply
Part # 250814*

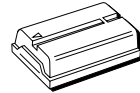

*Battery pack
Part # 247800*



*Lens cap
Part # 252975*



*Shoulder strap
Part # ACS091*

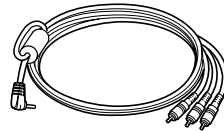

*Audio/ Video
adapter cable
Part # 252885*

Caution: Only use the power supply provided with this unit. Using other power supplies may damage the unit.

Buttons and Controls

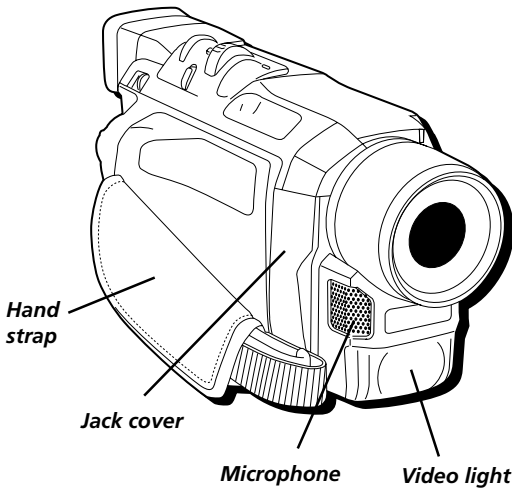
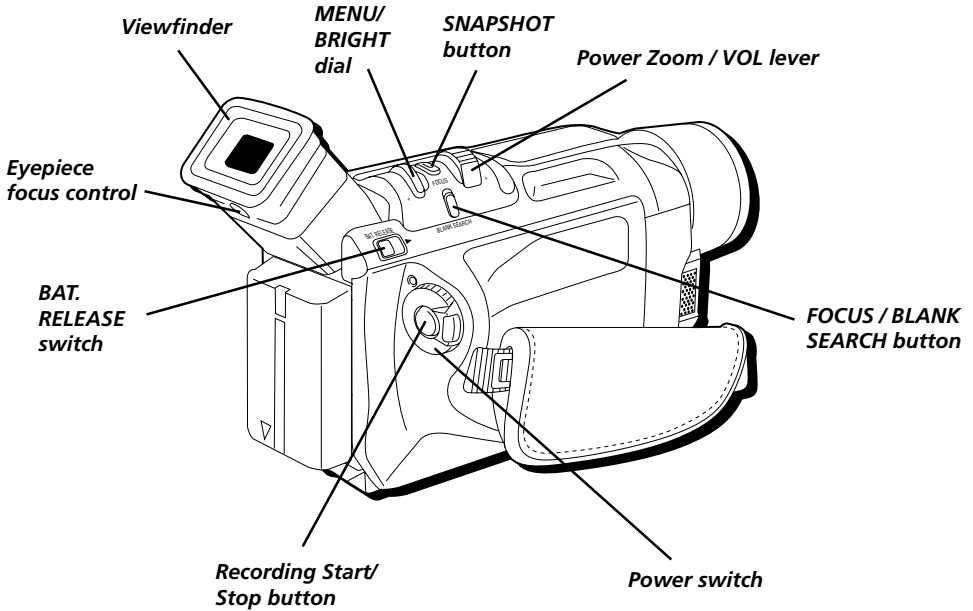

Connections & Setup

Playback buttons (also P.AE, NIGHT MODE, EXPOSURE, and BACK LIGHT buttons)

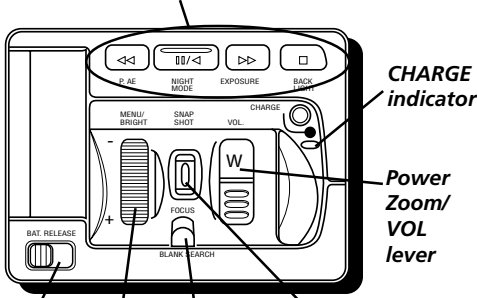

BAT. RELEASE switch
 MENU/BRIGHT dial
 FOCUS/BLANK SEARCH button
 SNAPSHOT button

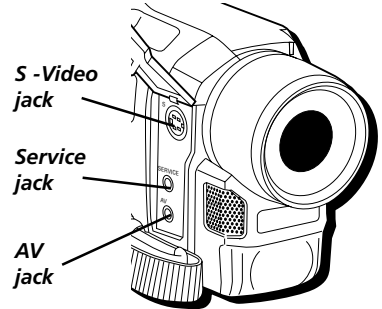

Jack cover open

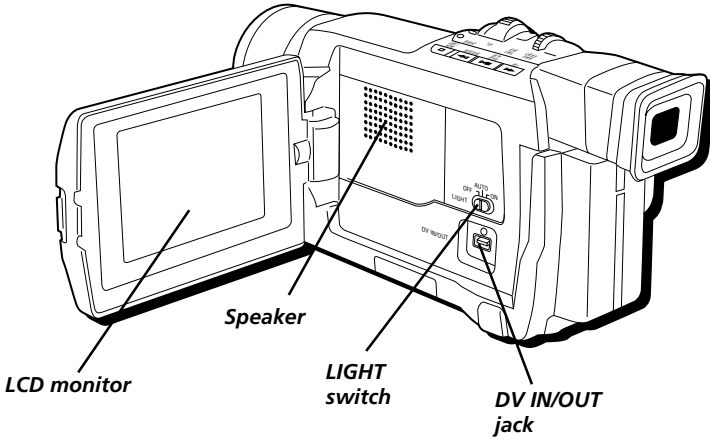

LCD monitor
 Speaker
 LIGHT switch
 DV IN/OUT jack

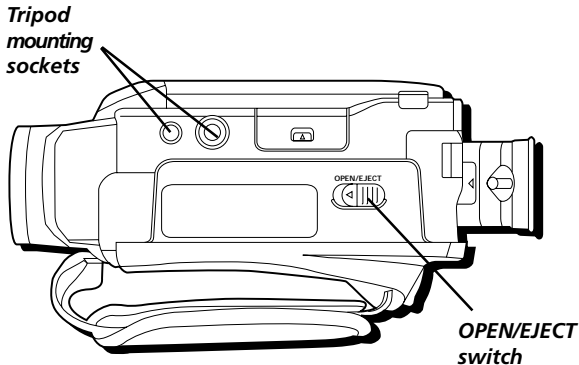

Camcorder bottom view

OPEN/EJECT switch

Getting Started

This section describes the basics on how to set up your camcorder to record for the first time. Refer to the other sections for detailed operation and feature options.

Unpack the camcorder and accessories

- The items shown are packed with the camcorder. If any pieces are missing or appear damaged, contact your dealer immediately.
- Remove the plastic film that covers the front and side logos on the camcorder. Use your fingernail, not anything sharp, to remove.
- Save all packing materials and box in case the camcorder ever needs to be shipped or stored.

Adjust the hand strap

1. Lift the flap on the hand strap and separate the Velcro strip.
2. Insert your hand so your fingers can comfortably reach the buttons.
3. Adjust the strap to fit snugly.
4. Refasten the strap, and fold the flap back down.

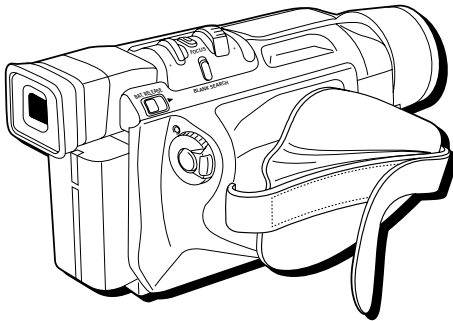

Connections & Setup

Attach the lens cap

To protect the lens, attach the provided lens cap to the camcorder as shown in the illustration.

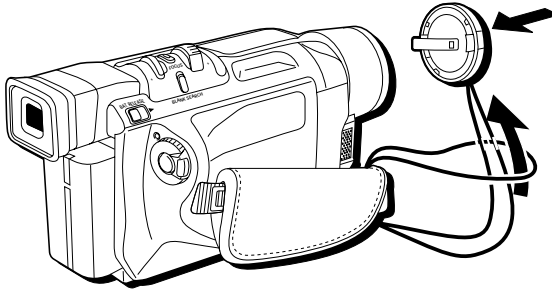

Attach the power supply

Since the battery must be charged before it can be used the first time, you need to use an AC outlet to power the camcorder.

1. Plug the small end of the power supply into the DC IN jack on the camcorder.
2. Plug the other end of the power supply into a working AC outlet.

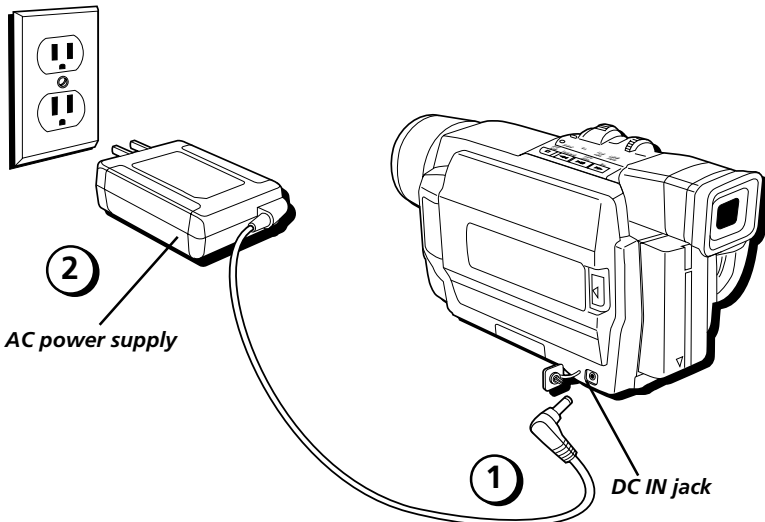

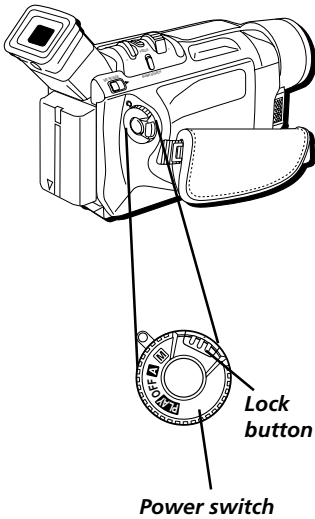

Turn on the camcorder

Press in the Lock button while setting the Power switch to the desired setting, either automatic (A) or manual (M) record mode, powered off (OFF), or in playback mode (PLAY).

The POWER indicator comes on when the camcorder is turned on.

Automatic recording A places the camcorder into AutoShot™ mode. Focus, exposure, iris control, and white balance are controlled by the camcorder during automatic recording.

Manual recording mode M allows you to control many of the camcorder's special features, including accessing the menus and setting the clock.

Notes:

- Many special effects don't operate in AutoShot mode (see pages 57-60 for more information).
- The camcorder automatically turns off to save battery power if you leave it in record-standby mode for more than five minutes. To turn it back on, set the Power switch to OFF, then back to automatic or manual record mode.

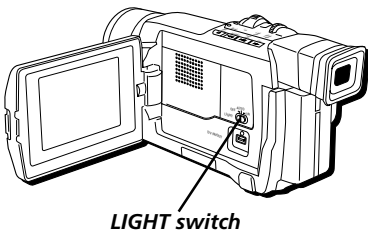

Set the LIGHT switch to AUTO

Slide the video LIGHT switch to AUTO. In this setting, the video light automatically turns on when more light is needed.

Mini DV NTSC

Mini DV Cassettes

This camcorder is designed to work exclusively with digital video cassettes. Only cassettes marked with a Mini DV logo can be used with this unit. Also keep in mind that this camcorder is not compatible with other digital media formats.

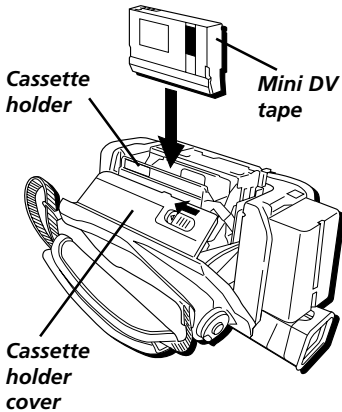

Insert a cassette tape

1. Make sure the camcorder is connected to a power supply.
2. Press in the Lock button while setting the Power switch to **A** (automatic record).
3. Slide and hold the OPEN/EJECT switch in the direction of the arrow then pull the cassette holder cover open until it locks. Be careful not to touch the inside of the cassette holder as you may hurt yourself.
4. Insert a Mini DV tape with the arrow on the tape facing down and the tape window facing out.

Note: Make sure the Erase Protection tab is in the position that allows recording. If not, slide the tab. Some tapes have removable tabs. If the tab has been removed, cover the hole with adhesive tape.

5. Push on the area marked PUSH HERE until the cassette holder locks into place. (*PAUSE* appears on the LCD or in the viewfinder.)

Once the cassette holder is closed, it recedes automatically. Wait until it recedes completely before closing the cassette holder cover.

6. To close the cover, slide and hold the OPEN/EJECT switch in the direction of the arrow again then close the cover until it firmly locks into place.

Important: If the battery is low, you may not be able to close the cassette holder cover. Do not apply force. Replace the battery with a fully charged one or connect the power supply.

Notes:

- You can't open the cassette tape holder unless a power supply is attached.
- The cassette tape holder can't be opened while the camcorder is in the record mode.

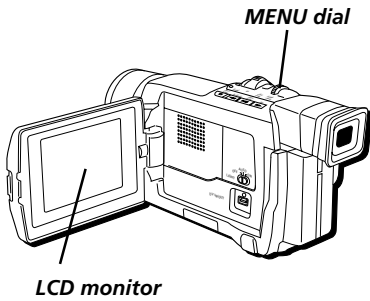

Use the LCD monitor or viewfinder to see what's recording

Using the LCD monitor

1. Remove the lens cap.
2. Open the monitor 90° from the camcorder body.
3. Tilt the monitor 180° forward or 90° down as required for convenient viewing while recording.
4. To adjust the brightness of the LCD monitor, rotate the MENU dial.

Notes:

- *Adjusting the LCD monitor brightness does not affect the recorded image on the tape.*
- *When the LCD monitor opens more than 25°, the viewfinder automatically turns off. When the LCD monitor is closed, the viewfinder automatically turns on.*

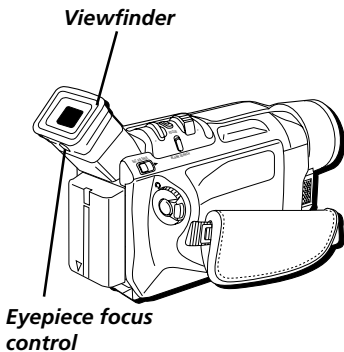

Using the viewfinder

1. Remove the lens cap.
 2. Close the monitor.
- Note:** *If the monitor is open more than 25°, the viewfinder turns off.*
3. Adjust the viewfinder to a comfortable position.
 4. Turn the eyepiece focus control to adjust the focus of the viewfinder for your vision.

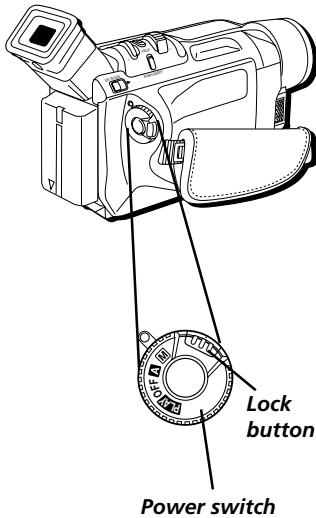

Start recording

1. Remove the lens cap.
2. Press in the Lock button and set the Power switch to **A** (automatic record). (The POWER indicator comes on.)
3. Press and release the Recording Start/Stop button to start recording. (*REC* appears in the viewfinder or LCD monitor (but won't be recorded)).
4. When finished recording, press and release the Recording Start/Stop button again to stop recording. The camcorder is now in the record-pause mode. (*PAUSE* appears in the viewfinder or on the LCD monitor.)

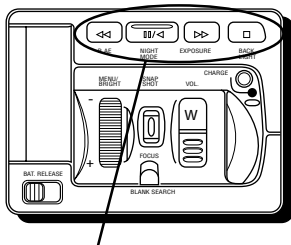

Playback buttons on top of the camcorder include:

Stop (■)

Rewind (◀◀)

Play/Pause (▶/||)

Fast Forward (▶▶)

Play your recording

1. Press in the Lock button while setting the Power switch to **PLAY**. (The POWER indicator comes on.)
2. Press the Rewind button ◀◀ to reverse the tape to the beginning. When rewound completely, the camcorder automatically stops.
3. Press the Play/Pause button ▶/|| to start playback. View the recording using the LCD monitor or viewfinder.
4. Press the Stop button ■ when finished playing the tape.

Notes:

- Sound will play back if the LCD monitor is open or closed. To adjust the volume, use the Zoom Lever (also labeled VOL - +).
- More information about using the LCD monitor and viewfinder can be found on pages 24-25.

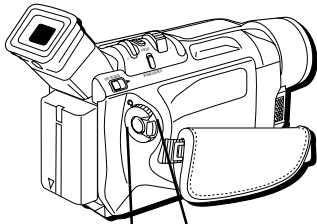

Power switch

Turn off the camcorder

1. Set the Power switch to OFF.
2. Close the LCD monitor.

Powering the Camcorder

You can power your camcorder with a battery or AC power.

Charging the Battery

1. Set the Power switch to OFF.
2. Raise the viewfinder.
3. Slide the battery into the back of the camcorder. Make sure the arrow diagram on the battery points down so that the contacts on the battery and camcorder match.

Important: If the battery pack is attached in the wrong position, a malfunction may occur.

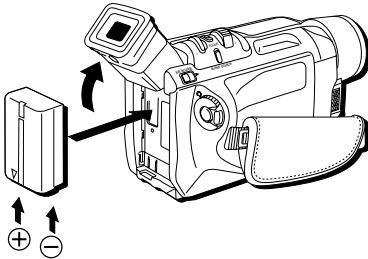

4. Plug the small end of the power supply into the DC IN jack on the camcorder and the other end into an AC outlet. (The CHARGE indicator blinks.)
5. When the CHARGE indicator stops blinking but stays on, charging is finished. Make sure the Power switch is set to OFF, then unplug the power supply from the AC outlet and from the camcorder.

Important: Before detaching the power source, make sure the camcorder's power is turned off. Failure to do so can result in a camcorder malfunction.

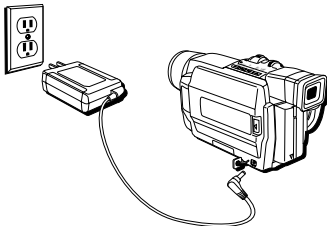

Notes:

- If a protective cap is on the battery, remove it before use or charging.
- When charging a battery for the first time or after a long storage period, the CHARGE indicator may not come on. Remove the battery and try again.
- Charge the battery in temperatures between 50° and 90° Fahrenheit (10-35° Celsius).
- Charging times are based on a fully discharged battery and vary depending on ambient temperature and battery conditions.

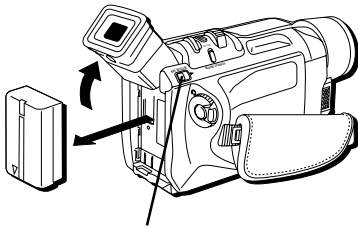

BAT. RELEASE switch

Removing the Battery

Raise the viewfinder, slide the BAT. RELEASE switch, and pull out the battery pack.

Notes:

- If you store a partially charged battery for a long period of time, its performance is reduced.
- During charging or discharging, the camcorder can't be operated.
- Charging and discharging isn't possible if the wrong type of battery is used.
- If the battery operation time remains extremely short even after having been fully charged, the battery is worn out and needs to be replaced. Please purchase a new one.

Tip

Before extended use, it is recommended that you prepare enough battery packs to cover 3 times the planned shooting time.

Approximate charging time

Battery	Charging Time
247800	approx. 90 min.

Approximate recording time (in minutes)

Battery	Viewfinder on	LCD monitor on
247800	75, (40*)	60, (35*)

* when the video light is on



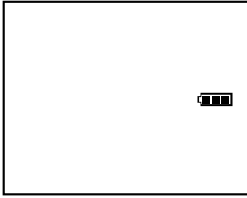

Note: Recording time is reduced significantly when you use the Zoom or Record-Standby modes repeatedly or when you use the LCD monitor repeatedly.



Battery Level Icon

The battery level icon appears in the viewfinder or LCD monitor and reveals the amount of power left in the rechargeable battery.

Note: *The battery level icon is not recorded on the tape.*

-  This icon appears when the battery is fully charged.
-  The icon changes to show that you've used some of the battery's power.
-  As you use more of the battery's power, the icon changes again.
-  This battery icon flashes in the viewfinder or LCD monitor when the battery power is almost gone. The camcorder turns off automatically after a few seconds.

Battery Care and Storage

- After repeated charging and use, battery life gradually decreases. When operation time is too short to be useful, the battery should be replaced.
- If the battery pack becomes too hot, remove it from the camcorder and let it cool down.
- Do not short the battery's terminals.
- Do not attempt to disassemble or modify the battery. There are no user-serviceable parts inside.
- Use the battery only with specified adapter/chargers and camcorders.
- Throwing the battery into a fire or exposing it to excessive heat – over 149°F (65°C) could be hazardous.

Using the Power Supply

The power supply attaches to the camcorder and lets you power it directly from standard household power. The power supply operates on 110-240 volts, 50/60 Hz.

1. Plug the small end of the power supply into the DC IN jack on the camcorder.
2. Plug the other end of the power supply into a working AC outlet (110-240V, 50/60Hz).

Caution: Only use the power supply provided with this unit. Using other power supplies may damage the unit.

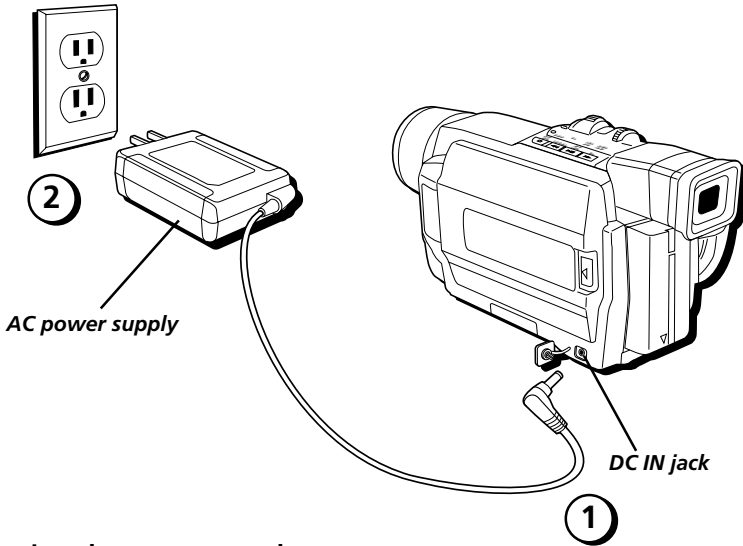

Removing the power supply

1. Make sure the Power switch is set to OFF.
2. Unplug the power supply from the AC outlet.
3. Unplug the small end of the power supply from the DC IN jack on the camcorder.

Important: Before detaching the power source, make sure the camcorder's power is turned off. Failure to do so can result in a camcorder malfunction.

Using an Optional Plug Adapter in Foreign Countries

An optional plug adapter might be required in some countries.

1. Plug the power supply's plug into the AC plug adapter.
2. Plug the AC plug adapter into the AC outlet.

Using the Shoulder Strap

The camcorder's shoulder strap is designed to let you carry the camera from your shoulder and – when ready– bring the camcorder to shooting position in one quick movement.

1. Following the illustration, thread the strap through the eyelet.
2. Fold the strap back and thread it through the buckle.
3. Repeat the procedure to attach the other end of the strap to the other eyelet located under the hand strap. Make sure the strap is not twisted.

Caution: When carrying the camcorder with the shoulder strap, you should close the LCD monitor and rotate the viewfinder down. This helps prevent possible damage to the monitor or viewfinder from bumping against your body as you move. Make sure the shoulder strap is firmly attached before using it to carry the camcorder.

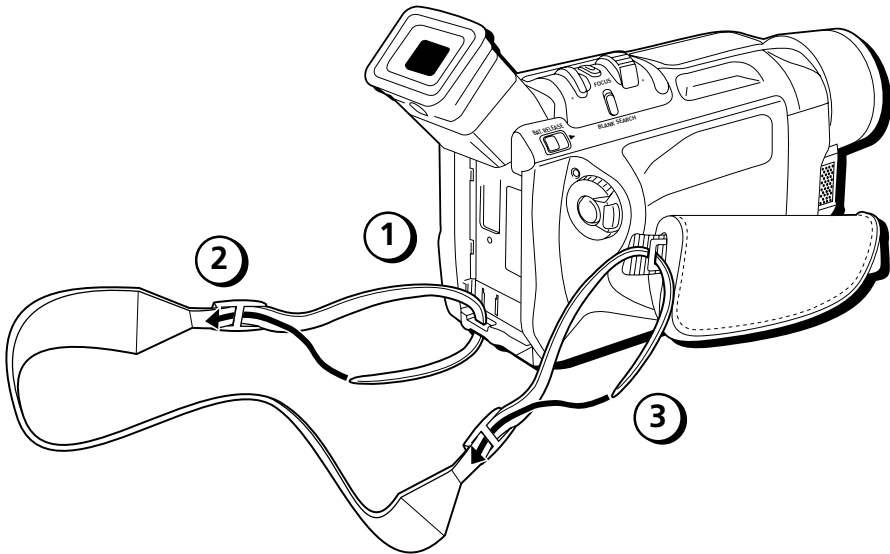

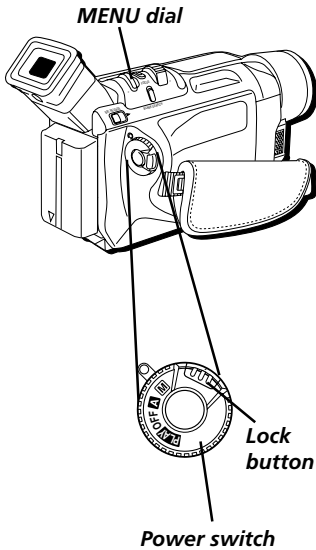

Setting the Date and Time

You need to set the date and time before it can be displayed.

Date and time information is recorded onto the tape at all times, but its display can be turned on or off during playback (see page 73).

1. Press in the Lock button while setting the Power switch to (manual record). (The POWER indicator comes on.)
2. Press in the MENU dial. (The Main Menu appears.)
3. Rotate the MENU dial to highlight *DISPLAY*. Press in the MENU dial to select it. (The Display Menu appears.)
4. Rotate the MENU dial to highlight *CLOCK ADJ.* Press in the MENU dial to select it. (The month is highlighted.)
5. Rotate the MENU dial to change the month. Press in the MENU dial to select it. (The date is highlighted.) Repeat to input the day, year, hour and minute.
6. When finished, press in the MENU dial twice to exit.

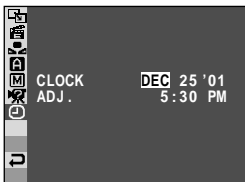
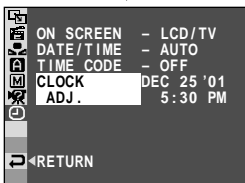
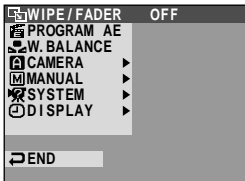

Notes:

- To make the date and time appear in the camcorder's display or on the TV, see page 73.
- The internal clock momentarily stops while you are entering the date/time information. It resumes once you finish.

Important: A separate internal battery is used for the time and date. Under normal conditions, this battery should last for 10 years or more. If you should need to replace it, see your nearest RCA authorized service center.

Using the Monitors

Chapter Overview:

- Seeing What You Are Recording
- On-screen Icons

Changing Entertainment. Again.



Seeing What You Are Recording

To see what is recording, use either the LCD monitor or the viewfinder monitor. When the LCD monitor is open more than 25°, the viewfinder turns off. When you close the LCD monitor, the viewfinder turns on.

Using the LCD Monitor

The camcorder's LCD monitor is a miniature color screen that you can use for recording playback.

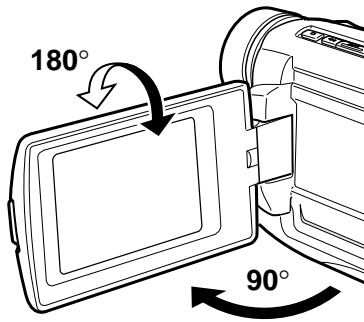

1. Open the LCD monitor at least 25°. The viewfinder turns off.
2. For convenient viewing, the LCD monitor can be tilted once it is open 90° from the camera body. Tilt the monitor forward up 180° or down up to 90°.
 - From a high angle (such as over a crowd)—tilt the monitor down to record.
 - From a low angle (such as when kneeling)—tilt the monitor up to record.
3. Adjust the brightness of the LCD monitor by turning the bright control (MENU dial). This doesn't affect the brightness of the recording you are making.
 - Turn the dial toward + to brighten the image.
 - Turn the dial toward – to darken the image.
4. When finished recording, close the monitor and lock it into place.

Note: Recording outdoors on bright, sunny days can make the LCD monitor hard to see. Use the viewfinder instead.

Cautions

Never force the LCD monitor to rotate completely around. This could damage both the monitor and/or the camcorder.

When carrying the unit with the shoulder strap, close the monitor to prevent possible damage to it.

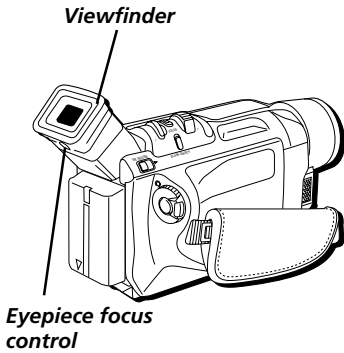

Using the Viewfinder

The camcorder's viewfinder is a miniature monitor that displays in black and white. For convenient viewing, rotate the viewfinder up or down.

Note: When the LCD monitor is open more than 25°, the viewfinder turns off.

Eyepiece Focus Control

The eyepiece focus control lets you set the focus of the viewfinder for your vision. If you wear eyeglasses, you probably can operate the camcorder without them.

It is easiest to set the correct focus by focusing on one of the viewfinder's on-screen displays. Look through the viewfinder and adjust the eyepiece focus control for your vision.

Note: The eyepiece focus control does not affect the focus of the image captured by the camcorder.

Cautions:

Never force the viewfinder to rotate completely around. This will damage the viewfinder and/or the camcorder.

When carrying the unit with the shoulder strap, put the viewfinder down to help prevent possible damage to it.

Using the Monitors

On-screen Icons

Several displays appear on the LCD monitor or in the viewfinder to aid in the operation of the camcorder. Although it may look crowded, all of the icons shown below do not appear on-screen at the same time. Also, not all screen icons are shown in the illustration. Refer to the icon descriptions that follow.

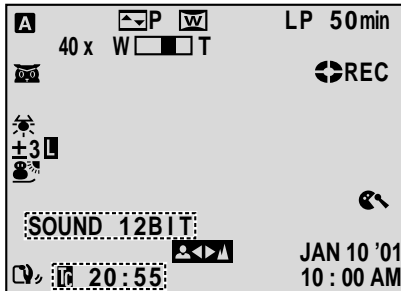

Recording Menu Icons

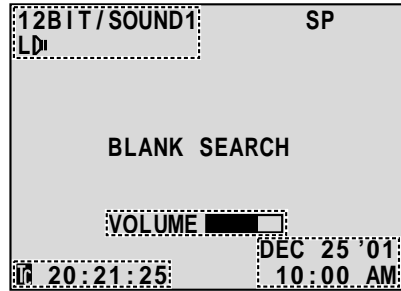

Playback Menu Icons

Warning Icons



Indicates the amount of power left in the rechargeable battery.



An empty battery icon flashes on screen when the battery's power is almost exhausted.



Missing Cassette: Appears when the Power switch is set to either **A** or **M** (automatic or manual record) and no cassette tape is in the camcorder.



Head Cleaning: *HEAD CLEANING REQUIRED USE CLEANING CASSETTE* appears if dirt is detected on the recording heads. Use an optional cleaning cassette to remove dirt.



Condensation: *CONDENSATION, OPERATION PAUSED PLEASE WAIT* appears if moisture occurs inside the camcorder. When this icon appears, remove the tape and wait at least one hour before using the camcorder again.

TAPE END

End of Cassette: Appears when a tape reaches its end during recording or playback.

DIFFERENT FORMATTED TAPE

Appears if a tape in another format is loaded.

SET DATE/ TIME!

Appears when the date and time is not set. May also occur if the internal clock battery needs to be replaced. See your nearest RCA authorized service center.

LENS CAP

Covered Lens: Appears briefly after the power is turned on to either automatic or manual record mode and the lens cap is still attached.

E01-E06

Safeguard: The error icons (E01-E06) show what type of malfunction has occurred. If an error icon and warning appear, turn the unit off, remove the power supply (battery, etc.) and wait a few minutes for the warnings to clear. If they do, you can resume using the camcorder. If the warnings remain, consult your nearest RCA authorized service center.

Recording and Playback Icons

Auto Date, Date, Time, or Date and Time Icons

DEC 25. 01 11:45 AM

Indicates the current date and time and is recorded when it is displayed (*see page 73*).

Using the Monitors

Program AE with Special Effects Icons

SHUTTER 1/60

Appears when you select *SHUTTER 1/60* to set the shutter speed to 1/60th of a second.

SHUTTER 1/100

Appears when you select *SHUTTER 1/100* to set the shutter speed to 1/100th of a second. May reduce flicker in some situations.

SPORTS

Appears when you select *SPORTS* to record fast-moving action, such as sporting events.

SNOW

Appears when you select *SNOW* to record scenes in bright surroundings, such as snow.

SPOTLIGHT

Appears when you select *SPOTLIGHT* to record scenes in direct lighting, such as spotlights.

TWILIGHT

Appears when you select *TWILIGHT* to record scenes at twilight, fireworks, etc.

SEPIA

Appears when you select *SEPIA* to give your recordings a brown-tone like old photographs.

B/W MONOTONE

Appears when you select *B/W MONOTONE* to record scenes in classic black and white.

CLASSIC FILM

Appears when you select *CLASSIC FILM* to record scenes with a slow-frame, classic movie feel.

STROBE

Appears when you select *STROBE* to record scenes in a series of consecutive snaps shots.

SLOW 4X

Appears when you select *SLOW 4X* to record scenes in dark lighting.

SLOW 10X

Appears when you select *SLOW 10X* to record scenes in darker lighting.

VIDEO ECHO

Appears when you select *VIDEO ECHO* to record scenes with a ghostly feel.

M. W. B. (Manual White Balance) Icons

The icon for the manual white balance selected in the *M.W.B.* menu appears here.



Appears when you select  :*FINE* to record outdoors on a sunny day.



Appears when you select  :*CLOUD* to record outdoors on a cloudy day.



Appears when you select  :*HALOGEN* to record using halogen or tungsten lighting.

MWB

MWB appears when you select  *MWB* to adjust the color temperatures.

Status Icons

REC

Appears when the camcorder is recording.

PAUSE

Appears during record-standby.



Appears when the camcorder plays a tape.



Appears during play-pause.



Appears during fast forward and flashes during forward search.



Appears during rewind and flashes during reverse search.

Using the Monitors

Zoom Icon

4X W  T

Appears when you use the zoom lever.

Bright and Volume Icons

BRIGHT

Appears when you adjust the brightness of the monitor with the **BRIGHT** dial.

VOLUME

During playback, the *VOLUME* icon appears when you adjust the volume of the speaker with the VOL control (also zoom lever).

12 BIT/SOUND1

L 

Displays the sound mode (either 12 or 16-bit).

Exposure Icon

+3

This icon appears when you are adjusting brightness manually using the *EXPOSURE* menu.

Iris Lock Icon

+3 

Appears when the iris is locked.

Fade and Wipe Icons

Press the FADE/WIPE button to display the icon for the fade or wipe you want to select.



Appears when you select white fade.



Appears when you select black fade.



Appears when you select black and white fade.



Appears when you select mosaic fade.



Appears when you select corner wipe.



Appears when you select window wipe.



Appears when you select slide wipe.



Appears when you select door wipe.



Appears when you select scroll wipe.



Appears when you select shutter wipe.



Appears when you select dissolve wipe.



Appears when you select corner wipe over the previous screen.



Appears when you select window wipe over the previous screen.



Appears when you select slide wipe over the previous screen.



Appears when you select door wipe over the previous screen.



Appears when you select scroll wipe over the previous screen.

Using the Monitors



Appears when you select shutter wipe over the previous screen.

Focus Icons



Appear when you are adjusting focus manually using the *FOCUS* menu. The icons also flash when the auto-focus system cannot operate properly or you can't adjust the focus any farther.

Other Icons

Steady Pix Icon



Appears when you are using Steady Pix™ (*see page 37*).

Tape Speed Icon

SP

Indicates what tape speed you have selected (*SP/LP*) (*see page 22*).

Time Code Icon

TC

Indicates the recorded time code (*see page 39*).

10:06:20

Time-Remaining Icon

120MIN

Indicates the approximate time remaining on the tape.

Recording

Chapter Overview:

- Recording Details
- Recording Tips

Changing Entertainment. Again.



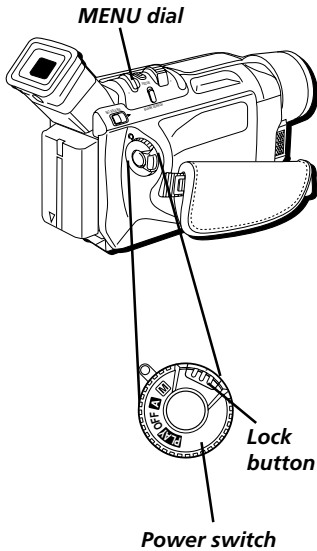

Recording Details

1. Remove the lens cap.
2. Press in the Lock button while setting the Power switch to **A** or **M** (automatic record or manual record mode). (The POWER indicator comes on.)
3. Open the LCD monitor or adjust the viewfinder.
4. Press and release the Recording Start/Stop button to start recording. (*REC* appears in the viewfinder or LCD monitor (but won't be recorded.))
5. When finished recording, press and release the Recording Start/Stop button again to stop recording. The camcorder is now in the record-pause mode. (*PAUSE* appears in the viewfinder or on the LCD monitor.)

Notes:

- *If the Record-Standby mode continues for 5 minutes without performing Zoom or any other operations, the camcorder's power shuts off automatically. Set the Power switch to OFF, and then back to **A** or **M** to turn the camcorder on again.*
- *To remove the icons from the camcorder's display during recording, see page 59.*

Journalistic Shooting

In some situations, different shooting angles may provide more dramatic results. Hold the camcorder in the desired position and tilt the LCD monitor in the most convenient direction. It can rotate 270° (90° downward, 180° upward).

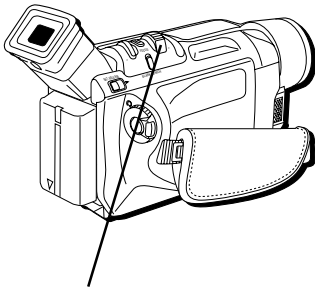

Zoom lever

Self-Recording

You can even record yourself while viewing your own image in the LCD monitor. Open the LCD monitor and tilt it upward 180° so that it faces forward, then point the lens toward yourself and start recording.

Digital and Optical Zooming

You can zoom in and out for close-up or wide-angle shots by moving the zoom lever on the camcorder. The camcorder automatically focuses at most distances when zooming. Optical zooming is possible up to 10 times, and digital zooming allows up to 400 times normal magnification.

Using the Zoom Lever (*W* and *T*)

To zoom in tight (telephoto) or out wide (wide angle), rotate the zoom lever to either *T* or *W*.

With telephoto zooming it is possible to capture images to a maximum of 400 times normal magnification. To do this, the camcorder uses technology to artificially enhance the image.

Optical zoom is the natural, non-enhanced magnification that the camcorder's lens will support. This camcorder has an optical zoom of 10 times (10X).

When using the zoom lever, an icon appears on screen to display the approximate zoom ratio.

Tip

The further you rotate the zoom lever, the quicker the zoom action.

Notes:

- *While zooming, focusing may become unstable. If so, set the zoom while in record-standby mode and adjust the image using manual focus (see page 71). Once the focus is set, zoom the camcorder in or out while recording.*
- *The zoom level icon moves during zoom. Once it reaches the end of the zoom icon bar, all magnification from that point is through digital processing.*
- *During digital zoom, the quality of the image may suffer.*

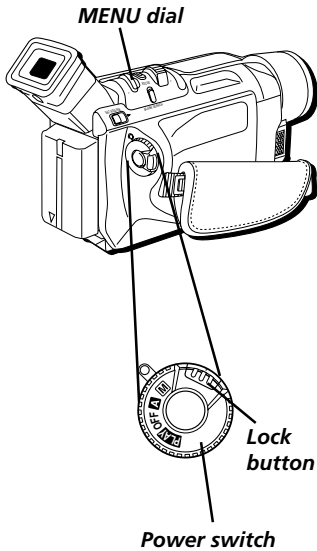

Using Digital Zoom

You can use digital zoom to magnify images to a maximum of 400 times normal magnification.

1. Press in the Lock button while setting the Power switch to **M** (manual record). (The POWER indicator comes on.)
2. Press in the MENU dial. (The Main Menu appears.)
3. Rotate the MENU dial to highlight *CAMERA*. Press in the MENU dial to select it. (The Camera Menu appears.)
4. Rotate the MENU dial to highlight *ZOOM*. Press in the MENU dial to select it. (The Zoom Menu appears.)
5. Rotate the MENU dial to highlight the desired setting. Press in the MENU dial to select it.
6. Press in the MENU dial twice to exit.

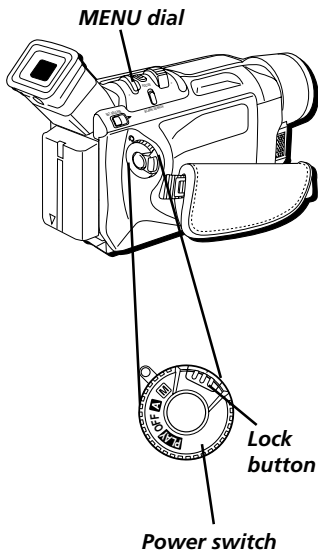

Using Steady Pix™

Digital Image Stabilization is used to compensate for unstable images caused by camera shake, especially at high magnifications.

1. Press in the Lock button while setting the Power switch to **M** (manual record). (The POWER indicator comes on.)
2. Press in the MENU dial. (The Main Menu appears.)
3. Rotate the MENU dial to highlight *MANUAL*. Press in the MENU dial to select it. (The Manual Menu appears.)
4. Rotate the MENU dial to highlight *DIS*. Press in the MENU dial to select it. (The Digital Image Stabilization Menu appears.)
5. Rotate the MENU dial to highlight the desired setting. Press in the MENU dial to select it.
6. Press in the MENU dial twice to exit.

Notes:

- *Accurate stabilization may not be possible if hand shake is excessive, or when recording the following:*
 - *subjects with vertical or horizontal stripes.*
 - *dark or dim subjects.*
 - *subjects with excessive backlighting.*
 - *scenes with movement in various directions.*
 - *scenes with low-contrast backgrounds.*
- *Switch off stabilization when the camcorder is mounted to a tripod.*
- *The  icon blinks or disappears if image stabilization can't be used.*

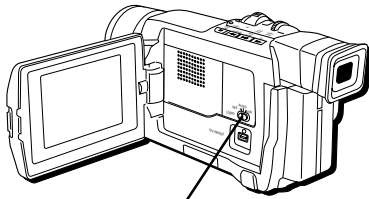

LIGHT switch

Using the Video Light

To brighten the scene when natural lighting is too dim, the camcorder uses a built-in video light.

You can turn on the video light at all times, set to turn on automatically when the camcorder senses additional light is needed, or turn off altogether.

Set the LIGHT switch as desired:

- OFF** Turns off the light.
- AUTO** Automatically allows the camcorder to turn on the light when there is insufficient lighting on the subject.
- ON** Keeps the light on at all times as long as the camcorder is turned on.

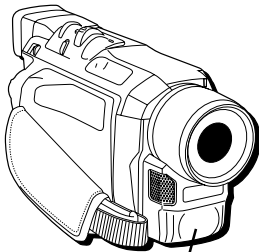

Video light

Video Light Details

Even if the battery icon (☐) doesn't blink due to low battery charge, the camcorder may turn off automatically when you turn on the video light, or if the video light is turned on when you start a recording.

When the LIGHT switch is set to *AUTO* :

- The video light may keep turning on and off depending on the lighting conditions. If this happens, manually switch the light to ON or OFF using the LIGHT switch.
- If the Sports mode and shutter are turned on, the video light is likely to stay on.
- While in Twilight mode and Night mode, the light won't activate.

Notes:

- *The video light can only be used when the camcorder is on.*
- *Set the white balance to artificial light (☀) when using the video light to avoid a "washed-out" look.*
- *When not using the video light, turn it off to save battery power.*



Cautions

- Never operate the video light closer than 1 foot to people or other objects.
- The video light becomes very hot. Do not touch it during use or right after use. Serious injury may result.
- Do not place the camcorder in a carrying case right after using the light.
- Never operate the video light close to flammable or explosive material.
- Consult your nearest RCA authorized service center to replace the video light.
- The video light and bulb need to cool for approximately 30 minutes after use before the bulb assembly is replaced.

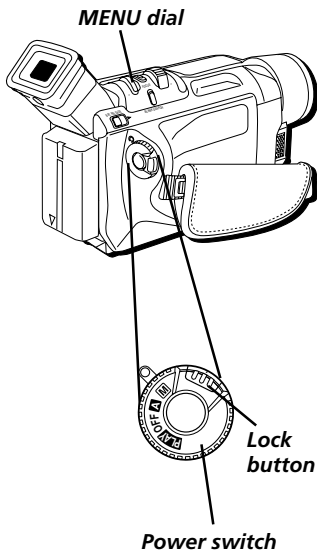

Time Code Display

During recording, a time code is captured on the tape. This code confirms the location of the recorded scene on the tape during playback.

If recording starts from a blank portion of the tape, the time code begins counting from 00:00:00 (minutes: seconds: frame number). If recording starts from the end of a previously recorded scene, the time code continues from the last time code number.

Note: The time code is automatically set to 00:00:00 when a tape is ejected.

1. Press in the Lock button while setting the Power switch to **M** (manual record). (The POWER indicator comes on.)
2. Press in the MENU dial. (The Main Menu appears.)
3. Rotate the MENU dial to highlight **DISPLAY**. Press in the MENU dial to select it. (The Display Menu appears.)
4. Rotate the MENU dial to highlight **TIME CODE**. Press in the MENU dial to select it. (The Time Code Menu appears.)
5. Rotate the MENU dial to highlight the desired setting. Press in the MENU dial to select it.
6. Press in the MENU dial twice to exit.

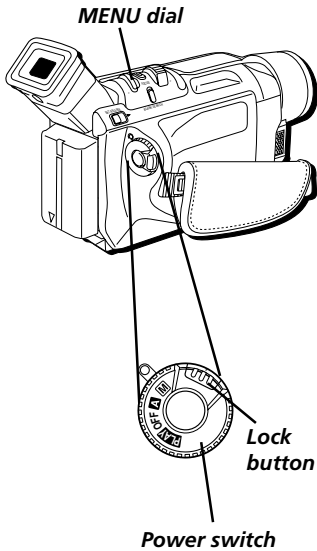

Selecting a Snapshot Mode

You can choose from 5 ways to display your digital pictures, including pin-up, frame, full, multi-4, and multi-9.

1. Press in the Lock button while setting the Power switch to **M** (manual record). (The POWER indicator comes on.)
2. Press in the MENU dial. (The Main Menu appears.)
3. Rotate the MENU dial to highlight *CAMERA*. Press in the MENU dial to select it. (The Camera Menu appears.)
4. Rotate the MENU dial to highlight *SNAP MODE*. Press in the MENU dial to select it. (The Snap Mode Menu appears.)
5. Rotate the MENU dial to highlight the desired setting. Press in the MENU dial to select it.
6. Press in the MENU dial twice to exit.



- Select *PIN-UP* to take a snapshot framed like a picture.



- Select *FRAME* to take snapshot within a frame.



- Select *FULL* to take a snapshot with no frame.

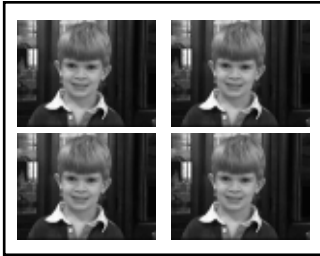

- Select *MULTI-4* to take four snapshots in a quick progression (giving the illusion of movement) and place all four images within one shot.

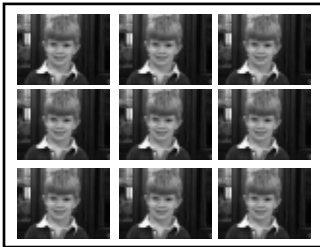

- Select *MULTI-9* to take nine snapshots in a quick progression (giving the illusion of movement) and place all nine images within one shot.

Note: *Snapshots taken in a dark area may become coarse and lose their true colors.*

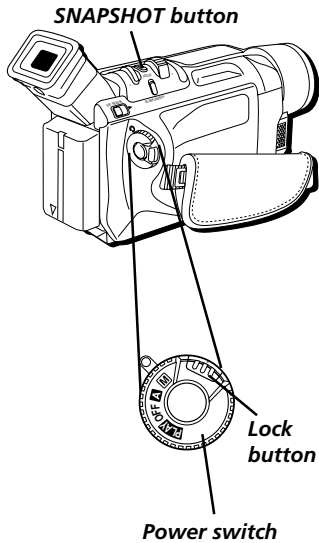

Taking Snapshots

1. Remove the lens cap.
2. Press in the Lock button while setting the Power switch to **A** or **M** (manual record). (The POWER indicator comes on.)
3. When you're ready to take a picture, press SNAPSHOT.

Notes:

- *To turn off the shutter sound, (see page 58).*
- *Snapshots taken using digital zoom or in the Night mode will be taken in the Full mode only.*
- *If a you can't take snapshot, PHOTO blinks when SNAPSHOT is pressed.*
- *Some Program AE Special Effects are not available in Snapshot mode.*
- *Digital Image Stabilization mode is not available in Snapshot mode.*
- *You may notice an image in the viewfinder may be partially missing while taking a snapshot, however, the snapshot will include the full image.*
- *Snapshots are taken in a format based on JPEG (Joint Photographic Experts Group).*
- *When you use the LCD monitor outdoors under direct sunlight, the LCD monitor may be difficult to see. If this happens, close the LCD monitor and use the viewfinder instead.*

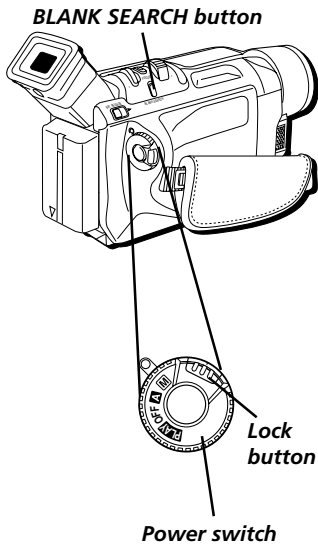

Blank Search

Helps you find where you start recording in the middle of a tape to avoid time code interruption.

1. Press in the Lock button while setting the Power switch to **PLAY** (playback mode). (The POWER indicator comes on.)
 2. Press BLANK SEARCH. (*BLANK SEARCH* appears and blinks, and the camcorder starts to search. The tape stops a few seconds before the next blank spot.
- To cancel Blank Search, press ■.

Notes:

- *If the current position is at a blank spot, the camcorder searches in the reverse direction. If the current position is at a recorded spot, the camcorder searches in the forward direction.*
- *If the beginning or end of the tape is reached during Blank Search, the camcorder stops automatically.*
- *A blank spot shorter than 5 seconds may not be detected.*
- *The detected blank spot may be located between recorded scenes. Before recording, double check that there is no recorded scene after the blank spot to avoid recording over it.*
- *Blank Search doesn't work if HEAD CLEANING REQUIRED. USE CLEANING CASSETTE appears when a tape is loaded.*

Recording Tips

- To improve picture quality and color reproduction, try to make sure indoor scenes are well-lit.
- Don't move the camcorder rapidly from side-to-side while recording. A steady, gradual "pan" avoids blurring and "jitter".
- Use the viewfinder or LCD monitor to make sure the camcorder is level while recording so that your scene isn't "tilted."
- Do not bump or tap the camcorder's microphone while recording as this sound will be recorded.
- Include close-ups of individuals when taping family outings or group functions.
- Fading in and out of scenes makes your videos appear more professional.
- Learn to use the special effects to add variety to your recordings.
- Be aware of video and audio backgrounds. Background details barely noticed while recording may show up as visual "clutter" on your recording. Background noises (especially TV sets, radios, household appliances, traffic sounds, etc.) might detract from the sound you want to record.
- Avoid long "still" shots of landmarks and scenic attractions. Recordings are more interesting if they include people and details. "Local color" gives travel videos lasting appeal. To add interest, consider recording a familiar or landmark scene from an unfamiliar vantage point.

Playback

Chapter Overview:

- Playback Options
- Choose Your Connection

Changing Entertainment. Again.



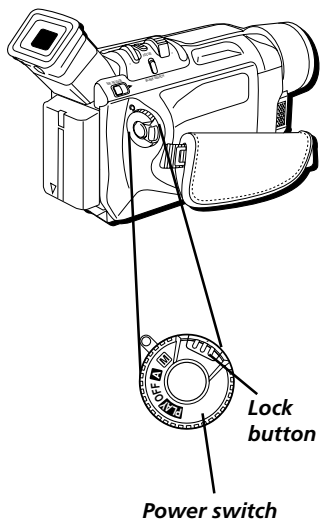

Playback Options

The camcorder's playback features include displaying still images and high-speed shuttle search. In this section, you'll also learn how to connect your camcorder to a TV or VCR.

Playback features (Play, Pause, Forward, Reverse, Stop) can be handled using the camcorder's buttons.

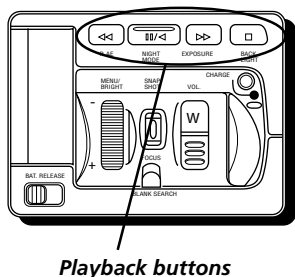

Playback buttons

Basic Playback

1. Insert a tape.
2. Press in the Lock button while setting the Power switch to **PLAY** (playback mode). (The POWER indicator comes on.)
3. Press **▶/||** (Play-Pause button) to start playback.
 - To stop playback, press **■** (Stop button).
 - Press **◀◀** (Rewind button) to reverse playback direction, or the **▶▶** (Fast Forward button) to advance the tape while in stop mode.



Notes:

- If stop mode continues for 5 minutes when power is supplied from a battery, the camcorder shuts off automatically to conserve power. To turn the camcorder on again, set the Power switch to OFF, then to back to **PLAY** (playback mode).
- When the Power switch is set to **PLAY** and the LCD monitor is opened at an angle of 25° or more, the LCD monitor switches on and the viewfinder switches off automatically to save power.

Tips

The playback picture can be viewed in the viewfinder (with the LCD monitor shut), on the LCD monitor, or on a connected TV (see page 50).

You can also view the playback picture on the LCD monitor with it flipped over and retracted.

- If a blank portion on the tape is played back, the screen may become black. This is not a malfunction.
- LCD monitor/viewfinder indications:
 - When power is supplied from a battery  appears. When power is supplied through the power supply,  does not appear.
 - When a tape is stopped, no icons appear.

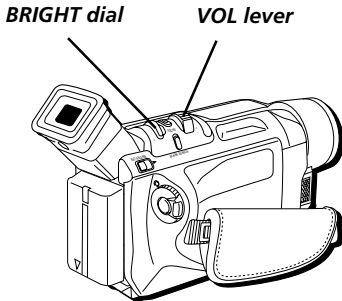

Adjusting the LCD Monitor Brightness

Rotate the BRIGHT dial towards + to brighten, or - to darken.

Controlling Speaker Volume

Slide the Zoom Lever (VOL.-+) towards + to turn up the volume, or towards - to turn down the volume.

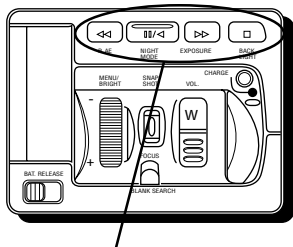

Playback buttons

Still Playback Mode

Still playback pauses the tape, freezing a single frame.

1. Press the Play/Pause button **▶/||** during playback to freeze the image.
2. To resume normal playback, press the Play/Pause button again.
 - If pause continues for more than a few minutes, the camcorder may turn off.
 - After approximately 5 minutes in stop mode, the power turns off automatically.

Shuttle Search

Shuttle search allows high-speed searching in either forward or reverse directions.

1. Press **▶▶** or **◀◀** during playback.
2. To resume normal playback, press **▶/||**.
 - During playback, press and hold **◀◀** or **▶▶**. The search continues as long as you hold down the button. Once released, normal playback resumes.
 - A slight mosaic effect appears on screen during shuttle search. This is normal.

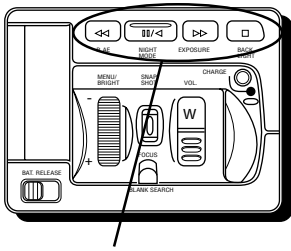

Playback buttons

Frame-By-Frame Playback

Allows frame-by-frame searching.

1. During playback, press **▶/||** to pause the image.
 2. For forward playback, rotate the MENU dial towards the +. For reverse playback, rotate the dial towards the -.
- To resume normal playback, press **▶/||** again.

Choose your Connection

This manual includes information for some basic types of connections. You may also need to refer to your TV and VCR user's guides for specific instructions.

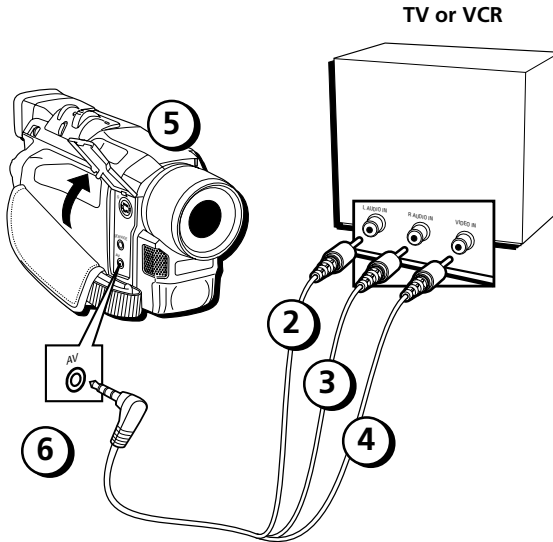

Connecting to a TV (or VCR) with Audio/Video Input Jacks

To connect your camcorder to a TV (or VCR) with audio/video inputs, you need to use the supplied audio/video cable. If your TV is already connected to a VCR, attach the camcorder to the VCR and watch what the camcorder is recording or playing on the TV.

1. Make sure all units are turned off before making any connections.
2. Connect the white plug of the audio/video cable to the left AUDIO IN jack on the TV (or VCR).
3. Connect the red plug of the audio/video cable to the right AUDIO IN jack on the TV (or VCR).
4. Connect the yellow plug of the audio/video cable to the VIDEO IN jack on the TV (or VCR).
5. Open the jack cover on the camcorder.
6. Connect the other end of the audio/video cable to the AV jack on the camcorder.

Note: Some VCRs or TVs do not offer both left and right audio jacks. For units with one audio jack, use the cable's white plug for audio.

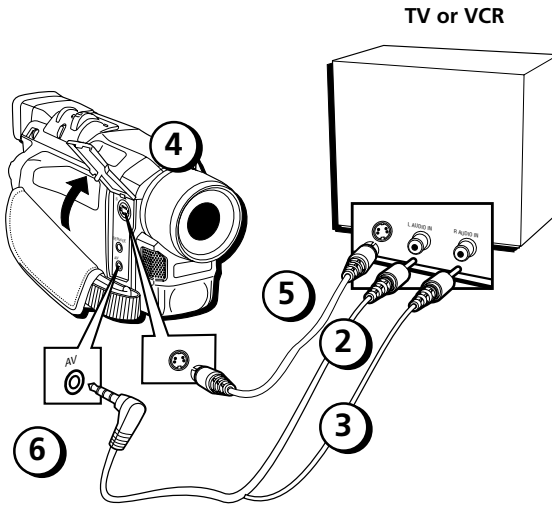

Note: The audio cables must also be used when using an S-video connection. The S-video cable only transfers video information.

Connecting to a TV (or VCR) with an S-Video Input Jack

To connect your camcorder to a TV (or VCR) with an S-Video input jack, you need to use an optional S-Video cable. If your TV is already connected to a VCR, attach the camcorder to the VCR and watch what the camcorder is recording or playing on the TV.

1. Make sure all units are turned off before making any connections.
2. Connect the white plug of the audio/video cable to the left AUDIO IN jack on the TV (or VCR).
3. Connect the red plug of the audio/video cable to the right AUDIO IN jack on the TV (or VCR).
4. Open the jack cover on the camcorder.
5. Connect one end of the optional S-Video cable to the S-Video jack on your TV (or VCR). Then connect the other end of the cable to the S-Video jack on the camcorder.
6. Connect the other end of the audio/video cable to the AV jack on the camcorder.

Note: Some VCRs or TVs do not offer both left and right audio jacks. For units with one audio jack, use the cable's white plug for audio.

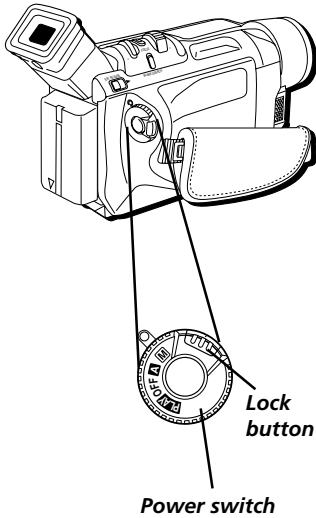

Playback on a TV (or VCR) with Audio/Video Input Jacks

1. Turn on the TV and tune it to the video input channel or turn on the VCR and place it in the “line” or “camera mode”. (If your VCR does not have a “line” or “camera mode”, consult the VCR user’s guide.) Operate the TV as you normally do to see the signal coming from the VCR.
2. Press in the Lock button while setting the Power switch to playback **PLAY** mode. (The POWER indicator comes on.)
3. Press **▶/||**.
 - During playback, use the playback features (see page 46).
4. Press STOP when you are finished.

Notes:

- *It is recommended to use the power supply instead of the battery pack for power to achieve uniform playback.*
- *Adjust the TV sound volume to its minimum level to avoid a sudden burst of sound when the camcorder is turned on.*
- *If you have a TV or speakers that are not specially shielded, do not place the speakers next to the TV as interference will occur in the camcorder playback picture.*
- *To view the picture and sound from the camcorder without recording, set the camcorder’s Power switch to **A** or **M**, then set your TV to the appropriate input mode.*

Dubbing to a VCR

1. Following the illustration in this chapter, connect the camcorder and the VCR.
2. Press in the Lock button while setting the camcorder's Power switch to **PLAY**, turn on the VCR's power, and insert the appropriate tapes in the camcorder and the VCR.
3. Make sure the VCR is in the appropriate AUX mode and the Record-Pause mode.
4. Use the camcorder's Play mode to find a spot just before the edit-in point. Once it is reached, press **▶/||** on the camcorder.
5. When you're ready to start recording, press **▶/||** on the camcorder and press the appropriate record button on the VCR.
6. When you want to stop recording, press the VCR's pause button and press **▶/||** on the camcorder.
7. Repeat steps 4 through 6 for additional editing, then stop the VCR and camcorder when finished.

Dubbing to Another Digital Video Camcorder

You can also copy a recording to another camcorder with a DV jack using an optional DV cable.

To Use this Camcorder as a Player:

1. Make sure all units are turned off before making any connections.
2. Connect one end of the optional DV cable to each digital camcorder.
3. Press the camcorder's Play/Pause button **▶/||** to start playback.
4. While watching the playback on the monitor, start the receiving camcorder's record mode from the spot on the source tape you want to begin recording.

Notes:

- *It is recommended to use the power supply instead of the battery for uniform playback.*
- *For digital dubbing, this camcorder can be connected to only one device at a time. This camcorder can also be used as the recording camcorder.*
- *If a blank portion or distorted image is played back during dubbing, the process may stop to avoid capturing problem images.*
- *Even though the DV cable is connected correctly, sometimes the image may not appear during playback. If this occurs, turn off the power and make connections again.*

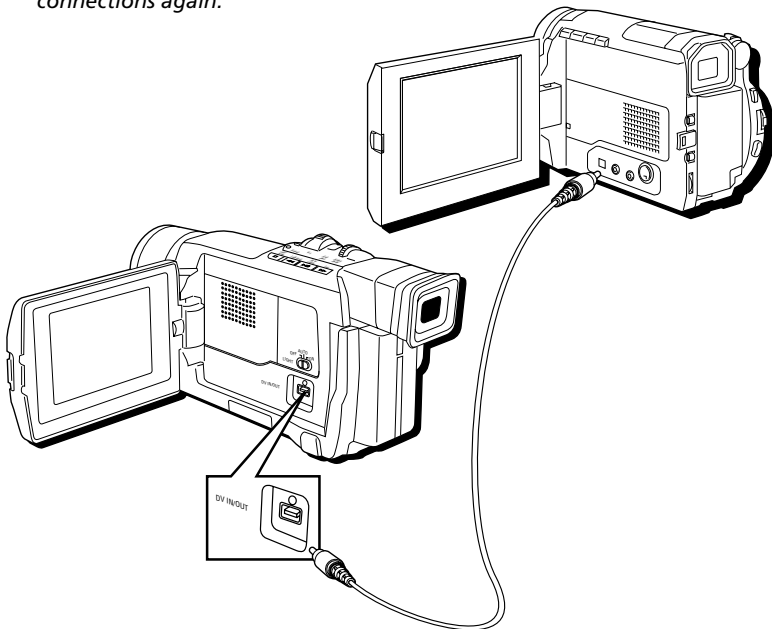

Advanced Features

Chapter Overview:

- Using the Menus for Advanced Adjustment
- Menu Definitions
- Using the Advanced Features

Changing Entertainment. Again.



Menu Definitions

The following charts will help you get acquainted with the various menus and some brief definitions of their features. For more detailed explanation, refer to the corresponding sections.

Main Menu

- WIPE/FADER** Refer to Fade/Wipe Effects (*see page 62*).
- PROGRAM AE** Refer to Program AE with Special Effects (*see page 65*).
- W. BALANCE** Refer to White Balance Adjustment and Manual White Balance Operation (*see pages 72-73*).

Camera Menu

The following settings are available in both **M** and **A** (manual and automatic record modes).

REC MODE		Allows you to set the recording speed (SP or LP) (<i>see page 22</i>).
SOUND MODE	12 BIT	Factory Preset: Enables video recording of stereo sound on four separate channels.
	16 BIT	Enables video recording of stereo sound on two separate channels.
ZOOM	10X	The optical zoom limit. When 10X is set, digital zoom is not used.
	40X	Factory Preset: Allows you to use the Digital Zoom. By digitally processing and magnifying images, zooming is possible from 10X (the optical zoom limit), to a maximum of 40X digital magnification.
	400X	Allows you to use the Digital Zoom. By digitally processing and magnifying images, zooming is possible from 10X (the optical zoom limit), to a maximum of 400X digital magnification.
SNAP MODE		Refer to Snapshot (<i>see page 40</i>).
GAIN UP	OFF	Allows you to shoot dark scenes with no picture brightness adjustment.
	AGC	Factory Preset: The image is bright, but the appearance may be somewhat grainy.
	AUTO	The shutter speed is automatically adjusted (1/30—1/200 sec.). Shooting a subject in low or poor lighting at 1/30 sec. shutter speed provides a brighter image than in the AGC mode, but the subject's movements are not smooth or natural. The overall appearance may be grainy. While the shutter speed is being automatically adjusted, ⚡A is displayed.

Advanced Features

Manual Menu

The following settings are available only in **M** (manual record mode).

DIS	OFF	Factory Preset: Refer to Using Steady Pix™ (see page 37).
	ON	
TELE MACRO	OFF	Factory Preset (OFF) : Usually the distance to a subject where the lens is in focus depends on the zoom magnification. Unless there is a distance of more than 1 m (3.3 ft) to the subject, the lens is out of focus at the maximum telephoto setting. When set to ON, you can shoot a subject as large as possible at a distance of approximately 60 cm (2 ft.). Depending on the zoom position, the lens may go out of focus.
	ON	
WIDE MODE	OFF	Factory Preset: Doesn't display black bars.
	CINEMA	Allows you to record black bars at the top and bottom of the screen to produce a cinema-like wide-screen effect.
	SQUEEZE	For 16x9 aspect-ratio TVs. Naturally expands the image to fit the screen without distortion.
WIND CUT	OFF	Factory Preset: Sound is recorded as normal without preventing wind noise.
	ON	Cuts down on the noise created by the wind.

System Menu

The following settings are available only in **PLAY** and **M** (manual record mode).

BEEP	OFF	Beeps are turned off and shutter sound is not heard.
	BEEP	Beeps sound when any operation is performed and shutter sound is heard during snapshots.
	MELODY	Factory Preset: A melody is heard instead of a beep when any action is performed and shutter sound is heard during snapshots.
TALLY	OFF	The tally light remains off at all times.
	ON	Factory Preset: The tally light comes on to indicate the start of a recording.
ID NUMBER		This number is necessary when connecting the camcorder to a device such as a computer using the service port. The numbers range from 01 to 99. Factory preset is 06.

DEMO MODE	ON	<p>Factory Preset: Demonstrates certain functions automatically. When <i>DEMO MODE</i> is set to <i>ON</i> and you have exited all menus, the demonstration starts. Operating the Power zoom lever during the demonstration stops the demonstration temporarily. If the Power zoom lever is not moved for more than 1 minute after that, the demonstration will resume.</p> <p>To cancel the demo mode, rotate the Power switch to M (manual record) and press in the MENU dial while the demo is in progress. Rotate the MENU dial to highlight SYSTEM. Press in the MENU dial to select it. (The System Menu appears.) Rotate the MENU dial to highlight DEMO MODE. Then press in the MENU dial to select it. Rotate the MENU dial to highlight OFF. Then press in the MENU dial again to select it.</p> <p>Note: When a tape is loaded in the camcorder, the demonstration is not available.</p>
	OFF	Automatic demonstration will not take place.
CAM RESET	CANCEL	Factory Preset: Does not reset all settings to the factory presets.
	EXECUTE	Reset all settings to the factory presets.

Display Menu

ON SCREEN	LCD	Displays most information from the camcorder's display on the LCD monitor. The only info to be displayed on a connected TV is the date, time, and time code.
	LCD/TV	Factory Preset: Displays the information from the camcorder's display on both the LCD monitor and a connected TV.
DATE/TIME	OFF	The date/time does not appear.
	AUTO	<p>Factory Preset: Displays the date/time for approx. 5 seconds in the following cases:</p> <ul style="list-style-type: none"> • When the Power dial is set from OFF to A or M. • When video playback starts. The camcorder displays the date/time when scenes are recorded. • When the date is changed during video playback.
	ON	The date/time is always displayed.

Advanced Features

TIME CODE	OFF	Factory Preset: Time code is not displayed.
	ON	Time code is displayed on the camcorder and a connected TV. Frame numbers are not displayed during recording.
CLOCK ADJ.		Allows you to set the current date and time.



Notes:

- The System and Display functions which are set when the Power switch is set to **M** (manual record) are also applied when the Power switch is set to **PLAY**.
CLOCK ADJ. only appears when the Power switch is set to **M**.
- The Display settings are effective even when the Power switch is set to **A**.

Using the Advanced Features

Night Mode

This feature can make dark subjects or areas even brighter than they would be under good, natural lighting. Although the recorded image is not grainy, it may look as if it is strobing due to the slow shutter speed.

1. Press in the Lock button while setting the Power dial to **M** (manual record).
2. Press NIGHT MODE. (The Night Mode icon  appears.)
 - The shutter is automatically adjusted to provide up to 30 times sensitivity.
 - The **A** icon appears beside  while the shutter speed is being automatically adjusted.
3. When finished using Night Mode, press the NIGHT MODE button again. (The Night Mode icon disappears.)

Notes:

- *During Night Mode, the following functions or settings cannot be activated:*
 - Some modes of Program AE and wiper/fades
 - Gain Up
 - Steady Pix™
 - The video light when set to AUTO
- *During Night Mode, it may be difficult to bring the camcorder into focus. A tripod may be necessary to prevent this.*

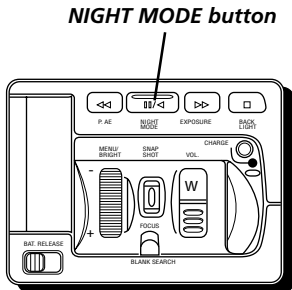
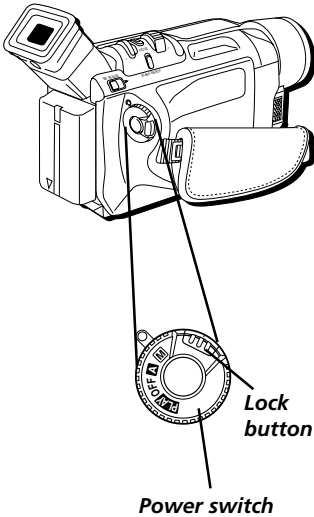

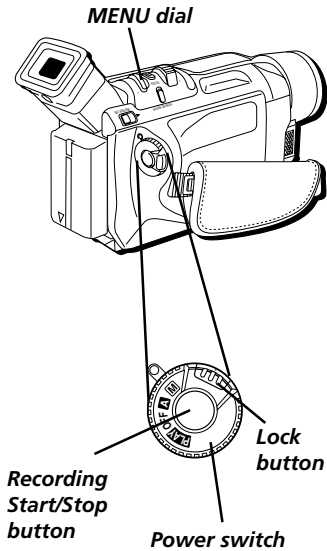

Fade/Wipe Effects

These effects let you make professional-looking scene transitions. Fade-ins or wipe-ins work at recording start, and fade-outs or wipe-outs work at recording end.

1. Press in the Lock button while setting the Power switch to **M** (manual record). (The POWER indicator comes on.)
 2. Press in the MENU dial. (The Main Menu appears.)
 3. Rotate the MENU dial to highlight *WIPE/FADER*. Press in the MENU dial to select it. (The Wipe/Fade Menu appears.)
 4. Rotate the MENU dial to highlight the desired setting. Press in the MENU dial to select it.
 5. Press in the MENU dial again to exit. (The corresponding icon for the wipe/fade you selected appears.)
 6. Press the Recording Start/Stop button to activate fade-in/out or wipe-in/out.
- To cancel a fade or wipe, select *OFF* in step 4.)

Fades

WH FADER-WHITE

Fades in/out to a white screen.

BK FADER-BLACK

Fades in/out to a black screen.

B.W FADER-B.W

Fades in to a color screen from black and white.
Fades out from a color screen to black and white.

MOSAIC

Gradually turns/returns the picture into/from a mosaic pattern.

Wipes

WIPE-CORNER

Wipes in on a black screen from the upper right to the lower left corner, revealing the scene. Wipes out from lower left to upper right, leaving a black screen.

WIPE-WINDOW

Wipes in on a black screen from the center of the screen towards the corners, revealing the scene. Wipes out from the corners to the center, leaving a black screen.

WIPE-SLIDE

Wipes in as a black screen moves in from the left to gradually cover the image. Wipes out as a new image moves in from right to left.

WIPE-DOOR

Wipes in as the two halves of a black screen open to the left and right, revealing the scene. Wipes out and the black screen reappears from left and right to cover the scene.

WIPE-SCROLL

Wipes in from the bottom to the top of a black screen. Wipes out from the bottom to the top, leaving a black screen.

WIPE-SHUTTER

Wipes in as a black screen from the top and bottom, closing over the image like a shutter. Wipes out as a new image, pushing open the black screen vertically from the center.

DISSOLVE

The new scene gradually appears as the old one gradually disappears.

WIPE-CORNER

The new scene wipes in over the previous one from the upper right corner to the lower left corner.

WIPE-WINDOW

The next scene gradually wipes in from the center of the screen toward the corners, covering the previous scene.

Advanced Features

WIPE-SLIDE

The next scene gradually wipes in over the previous scene from the right to the left.

WIPE-DOOR

The previous scene wipes out from the center to the right and left, like a door being pushed open to reveal the next scene.

WIPE-SCROLL

The new scene wipes in over the last one from the bottom to the top.

WIPE-SHUTTER

The new scene wipes in over the previous one from the center toward the top and bottom of the screen.

Note: *Pressing and holding the Recording Start/Stop button allows you to vary the length for the image during fade in/out or wipe in/out.*

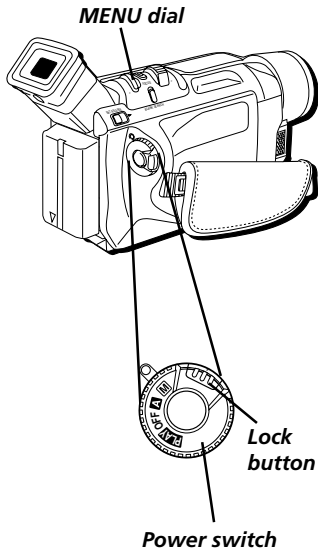

Program AE With Special Effects

1. Press in the Lock button while setting the Power switch to **M** (manual record). (The POWER indicator comes on.)
 2. Press in the MENU dial. (The Main Menu appears.)
 3. Rotate the MENU dial to highlight *PROGRAM AE*. Press in the MENU dial to select it. (The Program AE Menu appears.)
 4. Rotate the MENU dial to highlight the desired setting. Press in the MENU dial to select it.
 5. Press in the MENU dial again to exit.
 6. Press the P. AE button to activate the effect. (The icon for the effect appears.)
- To cancel an effect, press P. AE again.

Notes:

- *Only one mode can be engaged at a time.*
- *Program AE with special effects can be changed during recording or during Record-Standby.*
- *Some modes of Program AE special effects cannot be used during Night Mode or with certain Fade/Wipe effects.*

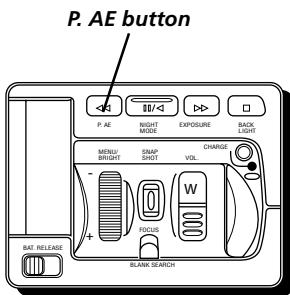

1/60 SHUTTER

The shutter speed is fixed at 1/60th of a second. Black bands that usually appear when shooting a TV screen become narrower.

1/100 SHUTTER

The shutter speed is fixed at 1/100th of a second. The flickering that occurs when shooting under a fluorescent light or mercury-vapor lamp is reduced.

Advanced Features

SPORTS

High shutter speed clearly captures fast-moving action.

SNOW

Useful when recording scenes in bright surroundings, such as snow, where subjects might otherwise appear too dark.

SPOTLIGHT

Useful when recording scenes in strong direct lighting, such as spotlights, where subjects might otherwise appear too bright.

Note: *Spotlight has the same effect as -3 using the exposure control.*

TWILIGHT

Dusk, twilight scenery, fireworks, etc., look more natural and dramatic. When Twilight mode is selected:

- Auto gain control is turned off.
- White Balance is set to *FINE* (day mode), but can also be manually changed to another mode (*see page 72*).
- Auto Focus becomes available only in the range of 10 m (32 ft.) to infinity. To focus when the subject-to-camera distance is less than 10 m (32 ft.), use manual focusing (*see page 71*).

SEPIA

Recorded scenes have a brownish tint like old photos. Combine this with the Cinema mode for a classic look (*see page 58*).

B/W MONOTONE

Recorded scenes are shot in black and white. Combine this with the Cinema mode for a classic look (*see page 58*).



CLASSIC FILM

Recorded scenes have a slow-frame, classic movie feel.



STROBE

Recorded scenes appear as series of consecutive snapshots.



SLOW 4X

Useful when recording in dark environments.



SLOW 10X

Useful when recording in even darker environments.

Notes:

- *When using Slow, the image takes on a strobe-like effect.*
- *If the manual focus indicator blinks when Slow is used, adjust the focus manually and use a tripod.*



VIDEO ECHO

Recorded scenes have a ghostly feel. Zoom magnification of over 10X is not available.

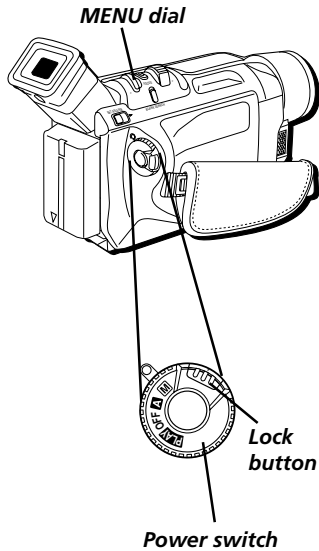

Exposure Control

This feature automatically adjusts the iris for the best available picture quality, but you can override it and make the adjustment manually. Manual exposure adjustment is recommended in the following situations:

- When shooting using reverse lighting or when the background is too bright.
- When shooting on a reflective natural background such as at the beach or when skiing.
- When the background is overly dark or the subject light.

1. Press in the Lock button while setting the Power switch to **M** (manual record). (The POWER indicator comes on.)
2. Press EXPOSURE. (The exposure control icon appears.)



- To brighten the image, rotate the MENU dial downward. (The exposure control level counter increases (maximum +06)).
- To darken the image, rotate the MENU dial upward. (The exposure control level counter decreases (maximum -06)).

3. Press in the MENU dial to lock it in.

Notes:

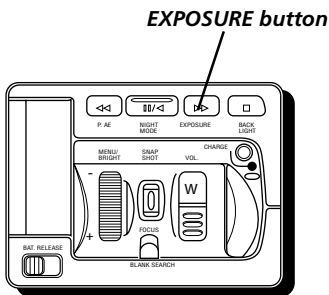
- To return to the automatic exposure, press EXPOSURE twice or set the Power switch to **A** (automatic record).
- To readjust exposure, repeat the procedure from step 2.



- To brighten the subject quickly, press the **BACKLIGHT** button on top of the camera in automatic exposure mode (this is also the rewind button). The  icon is displayed and the subject is brightened. If pressed again,  disappears and the brightness returns to the previous level. Backlight has no effect when using manual exposure.
- +3 exposure value has the same effect as using the backlight button.
- Using backlight may cause the light around the subject to become too bright and the subject too overexposed.
- When manual exposure is used, Spotlight and Snow also have no effect.

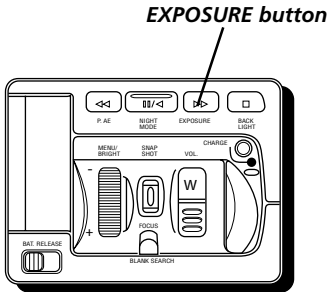

Iris Lock

The iris controls the amount of light that enters the camcorder.

Use Iris Control in the following situations:

- When shooting a moving subject.
- When the distance to the subject changes (so its size in the LCD monitor or viewfinder changes), such as when a subject is backing away.
- When shooting a reflective, natural background such as at the beach or when skiing.
- When shooting subjects under a spotlight.
- When zooming.

When the subject is close, keep the iris locked. Even when the subject moves away from the camcorder, the image will not darken or lighten.

1. Press in the Lock button while setting the Power switch to  (manual record). (The POWER indicator comes on.)
2. Press EXPOSURE. (The exposure control icon appears.)

3. Adjust zoom so the subject fills the screen, then press and hold the MENU dial for more than two seconds. (The exposure control indicator and the Iris Lock icon (🔒) appear).
4. Press in the MENU dial again to select it and the 🔒 icon changes to 📁. The iris is locked.



Notes:

- *To return to the automatic iris control, press EXPOSURE twice or set the Power switch to **A** (automatic record).*
- *To lock the exposure control and the iris, after step 2 of Iris Lock, adjust the exposure by rotating the MENU/BRIGHT dial. Then, in step 3, lock the iris. For automatic locking in step 2, press and hold the MENU dial. The iris becomes automatic after about 2 seconds.*

Focusing

Auto Focus

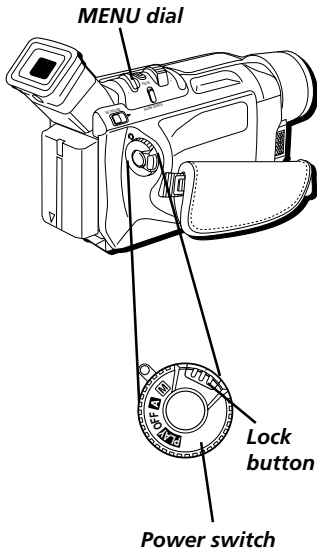

The camcorder's Full Range automatic focus system offers continuous shooting ability from close-up to infinity. However, correct focus may not be obtainable in the situations listed below (in these cases use manual focusing):

- When two subjects overlap in the same scene.
- When illumination is low. The low-contrast warning  appears.
- When the subject has no contrast (difference in brightness and darkness), such as a flat, one-color wall, or a clear, blue sky. The low-contrast warning  appears.
- When a dark object is barely visible in the viewfinder. The low-contrast warning  appears.
- When the scene contains small patterns or identical patterns that are regularly repeated.
- When the scene is affected by sunbeams or light reflecting off the surface of a body of water.
- When shooting a scene with a high-contrast background.





Manual Focus

Make the necessary viewfinder adjustments to use the viewfinder (*see page 25*).

1. Press in the Lock button while setting the Power switch to **M** (manual record). (The POWER indicator comes on.)
2. Press FOCUS. (The manual focus icon  appears.)
 - To focus on a subject that's farther away, rotate the MENU dial downward.  appears and blinks.
 - To focus on a nearer subject, rotate the MENU dial upward.  appears and blinks.
3. When finished, press in the MENU dial again to exit.

Notes:

- If the lens is smeared or blurred, accurate focusing isn't possible. Keep the lens clean, wiping it with a piece of soft cloth if it gets dirty. If condensation occurs, wipe the lens with a soft cloth or wait for it to dry naturally.
- When shooting a subject close to the lens, zoom out first (*see page 35*). When zooming in the auto focus mode, the camcorder could automatically zoom out depending on the distance between the camcorder and the subject.
- To return to Auto Focus, press FOCUS twice or set the Power switch to **A** (automatic record) .
- To readjust Manual Focus, repeat the procedure from step 2.
- When the focus level cannot be adjusted any farther or closer,  or  blinks.

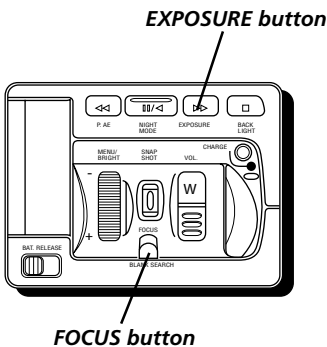

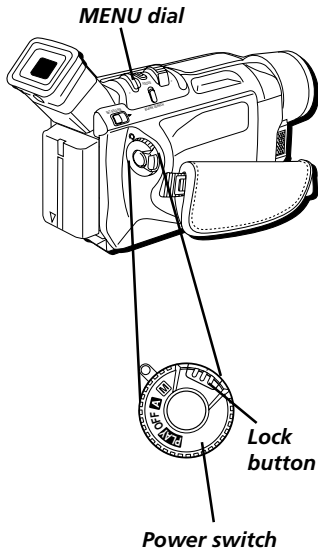

White Balance Adjustment

White balance refers to the correctness of color reproduction under various lighting. If the white balance is correct, all other colors will be accurately reproduced.

The white balance is usually adjusted automatically. However, more advanced camcorder operators control this function manually to achieve a more professional color/tint reproduction.

1. Press in the Lock button while setting the Power switch to **M** (manual record). (The POWER indicator comes on.)
2. Press in the MENU dial. (The Main Menu appears.)
3. Rotate the MENU dial to highlight *W. BALANCE*. Press in the MENU dial to select it. (The W. Balance Menu appears.)
4. Rotate the MENU dial to highlight the desired setting. Press in the MENU dial to select it.
5. Press in the MENU dial again to exit. (The corresponding icon for the white balance you selected appears.)

AUTO

White balance is adjusted automatically (factory preset).

MWB

White balance is set manually.

FINE

Outdoors on a sunny day.

CLOUD

Outdoors on a cloudy day.

HALOGEN

A video light or similar type of lighting is used.

Notes:



- To return to automatic white balance, select AUTO in step 4. Or rotate the Power switch to  (automatic record).
- White balance cannot be used when the SEPIA or MONOTONE mode is activated (see pages 66-67).

Manual White Balance

Perform Manual White Balance when shooting under various types of lighting.

1. Follow steps 1 through 4 of the white balance adjustment, and highlight  MWB.
2. Hold a sheet of plain white paper in front of the subject. Adjust zoom or position yourself so that the white paper fills the screen.

Note: *It may be difficult to focus on the white paper. In such a case, adjust focus manually (see page 71).*

3. Press in the MENU dial until  begins blinking rapidly. When the setting is complete,  resumes normal blinking.
4. When finished, press in the MENU dial twice to exit. (The manual white balance icon appears.)

Notes:

- *A subject can be shot under various types of lighting conditions indoors (natural, fluorescent, candlelight, etc.). Because the color temperature is different depending on the light source, the subject tint will differ depending on the white balance settings. Use this function for a more natural result.*
- *Once you adjust white balance manually, the setting is retained even if the power is turned off or the battery is removed.*

Date/Time Insert

You can display the date and time in the camcorder or on a connected TV, as well as to record it manually or automatically.

You should have already performed the Date/Time Setting procedure (see page 21).

1. Press in the Lock button while setting the Power switch to  (manual record). (The POWER indicator comes on.)
2. Press in the MENU dial. (The Main Menu appears.)
3. Rotate the MENU dial to highlight DISPLAY. Press in the MENU dial to select it. (The Display Menu appears.)
4. Rotate the MENU dial to highlight the desired setting. Press in the MENU dial to select it.
5. When finished, press in the MENU dial twice to exit.

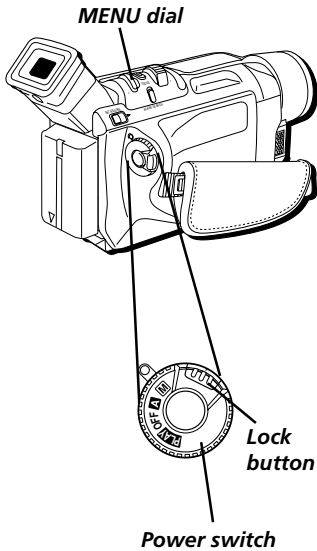

Notes:

ON

- The selected display can be recorded.
- If you do not want to record the display, select the OFF mode before shooting.

AUTO

- In this mode, the date is replaced after 5 seconds with AUTO but isn't recorded.
- Your camcorder automatically records the date for about 5 seconds after you do the following:
 - Change the date.
 - Load a tape.
 - Set the Power switch to **A**, **M**, or OFF.

Wide Mode

The camcorder lets you make recordings compatible with the 16x9 (wide screen) format. When Wide Mode is activated, the camcorder records black bars at the top and bottom of the picture to produce the wide-screen effect. This is also known as “letterbox” recording.

1. Press in the Lock button while setting the Power switch to **M** (manual record).
2. Press in the MENU dial. (The Main Menu appears.)
3. Rotate the MENU dial to highlight *MANUAL*. Press in the MENU dial to select it. (The Manual Menu appears.)
4. Rotate the MENU dial to highlight *WIDE MODE*. Press in the MENU dial to select it. (The Wide Mode Menu appears.)
5. Rotate the MENU dial to highlight the desired setting. Press in the MENU dial to select it.
6. When finished, press in the MENU dial twice to exit.



- Select *OFF* to record in normal mode suitable for standard TVs.



- Select *CINEMA* to insert black bands on the top and bottom of the screen.

Note: During playback on wide screen TVs, the black bands are cut and the screen ratio becomes 16x9. A  icon appears in the camcorder's LCD or viewfinder. During playback/recording on standard 4x3 TVs, viewfinders, or monitors, black bands appear like a letterbox 16x9 movie.



- Select *SQUEEZE* for playback on TVs with a 16x9 aspect ratio. This naturally expands the image to fit the screen without distortion. A  icon appears on the camcorder's LCD or viewfinder. In this mode, playback on a standard 4x3 TV, monitor, or viewfinder will display an elongated image.

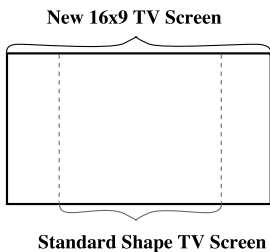

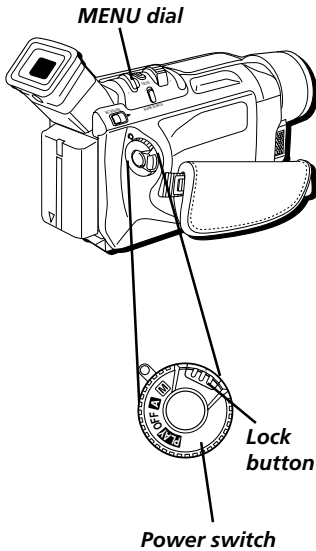

Wind Cut

To help cut down on the noise created by wind when shooting outside, use the Wind Cut feature.

Note: When using wind cut, the sound quality changes. This is normal.

1. Press in the Lock button while setting the Power Switch to **M** (manual record).
2. Press in the MENU dial. (The Main Menu appears.)
3. Rotate the MENU dial to highlight **MANUAL**. Press in the MENU dial to select it. (The Manual Menu appears.)
4. Rotate the MENU dial to highlight **WIND CUT**. Press in the MENU dial to select it. (The Wind Cut Menu appears.)
5. Rotate the MENU dial to highlight the desired setting. Press in the MENU dial to select it.
6. When finished, press in the MENU dial twice to exit.

Resetting the Camcorder Defaults

If you ever want to set the camcorder back to its original factory settings, use the Cam Reset function.

1. Press in the Lock button while setting the Power Switch to **M** (manual record).
2. Press in the MENU dial. (The Main Menu appears.)
3. Rotate the MENU dial to highlight **SYSTEM**. Press in the MENU dial to select it. (The System Menu appears.)
4. Rotate the MENU dial to highlight **CAM RESET**. Press in the MENU dial to select it. (The CAM RESET Menu appears.)
5. Rotate the MENU dial to highlight the desired setting. Press in the MENU dial to select it.
6. When finished, press in the MENU dial twice to exit.

Downloading to a PC

Chapter Overview:

- Connecting to a Computer

Changing Entertainment. Again.



Downloading to a PC

Connecting to a Computer

To transfer your still pictures and videos to your PC or Macintosh, you will need an optional DV cable, a suitably equipped computer with IEEE1394 connection (also known as Firewire), a DV card, and editing software equipped with your computer or commercially available software. Some newer computers are already equipped with this connection.

Minimum Requirements

- IEEE1394 Firewire-compatible PC interface, DV card, and editing software
- IEEE1394 Firewire cable

Note: You can order an IEEE1394 Firewire cable from the accessories section (see page 96).

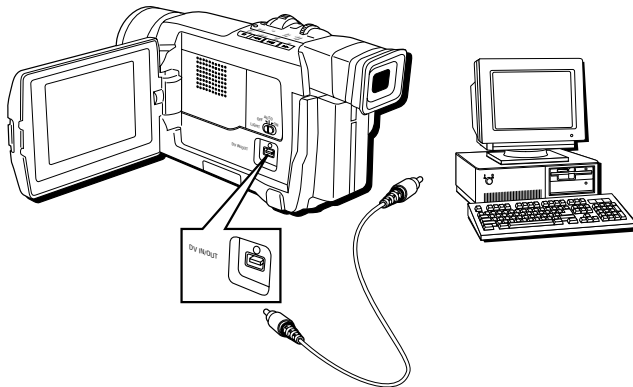

1. Make sure all units are turned off before making any connections.
2. Connect one end of the optional DV cable to your camcorder and the other end to the computer.
3. Press in the Lock button on the camcorder while setting the Power switch to **PLAY** (playback mode). (The POWER indicator comes on.)
4. Turn on the computer, open the application you want to use, and refer to the software user's guide of the application to transfer the still images or video.
5. When finished, close the software, then turn off the computer and camcorder.

Notes:

- Use the power supply instead of the battery pack to power the camcorder.
- The date/time information can't be transferred to the computer.
- For more information on how to download snapshots or video to your computer, refer to your DV card software user's guide.

Other Information

Chapter Overview:

- Troubleshooting
- Final Notes
- Care and Cleaning
- Traveling Tips
- Specifications
- Limited Warranty
- FCC and Industry Canada Information
- Optional Accessories
- Index

Changing Entertainment. Again.



Troubleshooting

If you're having problems with your camcorder, try the solutions in this section. If the problem still exists, please consult your nearest RCA authorized service center.

External noise and interference (from a TV, a radio, etc.) might prevent your camcorder from functioning properly. In such cases, first disconnect the power supply unit (battery pack, AC power supply, etc.); and then reconnect it and proceed as usual from the beginning.

Power Problems

No power is supplied.

- The battery pack has not been attached correctly (*see page 15*).
- The battery pack is not charged (*see page 15*).
- The power supply has not been correctly connected (*see page 10*).

The power suddenly goes off and does not come back on by itself.

- Turn the Power switch off and then on again.
- The battery pack has completely discharged.
- Remove the tape and disconnect the power source, then after a few minutes, try reconnecting and turning the power back on. If it still does not come on, consult your nearest RCA authorized service center.

Feature and Function Problems

Some menus or features are not available.

The Power switch is set to **A**. Set it to **M** and try again.

Vertical white lines appear when shooting a very bright object.

This sometimes occurs when there is a lot of contrast between the background and the object. It is not a defect of the camcorder. Try shooting from a different angle or adjusting the lighting conditions.

Bright, crystal-shaped spots appear in the LCD monitor and the viewfinder.

Sunlight is directly entering the lens. This is not a defect of the camcorder.

The rear of the LCD monitor is hot.

The light used to illuminate the LCD monitor causes it to be hot. Close the LCD monitor to turn it off or set the Power switch to OFF, and let the unit cool down.

Colored bright spots appear all over the LCD monitor or the viewfinder.

The LCD monitor and the viewfinder are made with high-precision technology. However, black spots or bright spots of light (red, green or blue) may appear constantly on the LCD monitor or in the viewfinder. These spots are not recorded on the tape. This is not due to any defect of the unit.

The icons and the picture color on the LCD monitor are not clear.

This may occur when the surface or the edge of the LCD monitor is pressed.

The LCD monitor, the viewfinder and the lens are dirty.

Wipe them gently with soft cloth. Gently wipe the LCD monitor in a semicircle because wiping strongly spreads the stain and it won't come out easily.

An error number (i.e. E03) appears.

Turn the camcorder's power off, then disconnect the power source. After a few minutes, try turning the power on again.

The image is out of focus.

The eyepiece focus control needs to be adjusted (*see page 25*).

The scene being shot is adversely affecting the operation of Auto Focus (*see page 70*).

Even though the lens cap is detached, the *LENS CAP* warning icon blinks.

The *LENS CAP* warning icon may blink when the camcorder is used in dark areas, regardless of whether the lens cap is attached or detached (*see page 27*).

Other Information

Recording Problems

Recording cannot be performed.

Make sure the Erase Protection tab is in the position that allows recording. If not, slide the tab. Some tapes have removable tabs. If the tab has been removed, cover the hole with adhesive tape.

Recording does not start.

The camcorder Power switch has not been set to **A** or **M** (*see page 11*).

Playback Problems

The tape is running, but there is no playback picture.

The TV has not been set to its VIDEO input channel.

If Audio/Video connection is used, the TV's VIDEO/TV switch has not been set to VIDEO.

Playback picture is blurred or interrupted.

The video heads are dirty or worn out. Consult your nearest RCA authorized service center for head cleaning or replacement.

Rewinding or fast-forwarding can't be performed.

The tape is already fully wound on one reel or the other.

The date and time displays disappear.

If you remove the power source from the camcorder while the power is on, all settings and selections are erased. Make sure to turn the camcorder's power off before disconnecting the power source.

The wrong date and time are displayed/recorded.

If you have not performed Date/Time Setting (*see page 21*), the date and time are not displayed/recorded correctly.

The tape won't eject.

The battery pack is running low.

Final Notes

Power

- Perform charging where the temperature is between 10°C and 35°C (50°F and 95°F). 20°C to 25°C (68°F to 77°F) is the ideal temperature range for charging. If the environment is too cold, charging may be incomplete.
- Charging times are for a fully discharged battery pack.
- Charging time varies according to the ambient temperature and the status of the battery pack.
- To avoid interference with reception, do not use the AC power supply near a radio.
- Since the AC power supply processes electricity internally, it becomes warm during use. Be sure to use it only in well-ventilated areas.
- The following stops charging or discharging:
 - Setting the Power switch to **PLAY**, **A**, or **M**.
 - Disconnecting the AC power supply from the camcorder.
 - Unplugging the AC power supply's cord from the AC outlet.
 - Detaching the battery from the camcorder.

Date/Time Settings

- The date/time cannot be stored in memory if the built-in clock battery runs out. Consult an authorized RCA dealer for replacement, or set the date/time as necessary before you start shooting.

Video Recording

- When the Power switch is set to **A** or **M** and the LCD monitor is opened at an angle of 25° or more, the LCD monitor switches on and the viewfinder switches off automatically to save power.
- The cassette tape holder can't be opened unless a power supply is attached.
- There may be a delay after you slide OPEN/EJECT until the cassette tape holder opens. Do not use force.
- The time required to calculate the remaining tape length, and the accuracy of the calculation, may vary according to the type of tape used.
- *TAPE END* appears when the tape reaches its end, and the power goes off automatically if left in this condition for 5 minutes.
TAPE END also appears when a tape is loaded and is already at its end.
- If the Recording Start/Stop button is pressed after the Record-Standby mode has continued for over 5 minutes, recording may not start immediately.
- While shooting, sound is not heard from the speaker.

Tapes

- A power supply must be attached to load or eject a tape.
- When loading a tape, it takes a few seconds for the cassette tape holder open. Never apply force to the holder or door cover as this might result in damage to the camcorder and void the warranty.
- If the cassette tape holder does not open after a few seconds, close the holder door and try again. If it still does not open, turn the camcorder off, then on again.
- If the tape does not load properly, open the cassette tape holder door and fully remove the unit. Wait a few minutes and reinsert it.
- When the camcorder is suddenly moved from a cold environment to a warm environment, wait a short time before opening the cassette tape holder door.
- Closing the cassette tape holder door before the holder comes out may damage the camcorder.
- Even when the camcorder is turned off, a tape can still be loaded or unloaded. After the cassette tape holder is closed with the camcorder switched off, though, it may not recede. **Turn the power on before loading or unloading tapes.**
- When recording, once the cassette tape holder door is open, a blank portion will be recorded on the tape or a previously recorded scene will be taped over regardless of whether the tape holder came out or not.

Care and Cleaning

After Using the Camcorder

1. Set the Power switch to OFF.
2. Slide and hold the OPEN/EJECT switch in the direction of the arrow then pull the cassette holder cover open until it locks. Remove the tape. Be careful not to touch the inside of the cassette holder as you may hurt yourself.
3. Push on the area marked PUSH HERE until the cassette holder locks into place. (*PAUSE* appears on the LCD or in the viewfinder.)

Once the cassette holder is closed, it recedes automatically. Wait until it recedes completely before closing the cassette holder cover.
4. To close the cover, slide and hold the OPEN/EJECT switch in the direction of the arrow again then close the cover until it firmly locks into place.
5. Close and lock the LCD monitor.
6. Slide the BAT. RELEASE switch and remove the battery pack.
7. Reattach the lens cap.

Cleaning The Camcorder

1. Clean the exterior, wiping gently with a soft cloth. For heavy dirt, use diluted, mild soap and wring the cloth well. Then wipe again with a dry cloth.
2. Open the LCD monitor and wipe it gently with a soft, dry cloth. Close it when done.
3. To clean the lens, blow it with air using a blower brush. Wipe gently with lens cleaning paper.
4. To clean the viewfinder, raise it to the vertical position. Carefully open the cover on the bottom of the viewfinder. Insert a lens blower or soft cloth into the gap to clean the interior. Close the cover and tilt the viewfinder back to the horizontal position.

Notes:

- *Avoid using strong cleaning agents such as alcohol.*
- *Cleaning should be done only after the power supply has been disconnected.*
- *Mold may form if the lens is left dirty.*
- *When using a cleaner or chemically treated cloth, refer to the cautions of each product.*

Proper Care and Storage

- Keep dirt from entering the camcorder's cassette tape door. Dust and grit are abrasive and cause excessive wear to both the recording/playback heads and tapes.
- Always cap the lens when the camcorder is not in use.
- Before handling the camcorder, make sure your hands and face are free from any chemical products such as suntan lotion, as it might damage the finish.
- The camcorder might be damaged by improper storage or handling. Do not subject the camcorder to swinging, shaking, or dropping.
- Do not store the camcorder in temperatures below -22°F (-30°C) or above 149°F (65°C).
- When the camcorder is not in use, always remove the tape and AC power supply/charger or battery.
- Retain the original carton for future storage or shipping purposes.

Tape Care and Storage

- When finished with a tape, rewind it, remove it from the camcorder, and label it. Protect the tape using the erase protection tab if necessary.
- Store tapes vertically in their protective cases at normal room temperatures. Never leave the camcorder or tapes in a car or outdoors for an extended period of time. Excessive heat or cold might damage tapes.
- Keep tapes away from strong magnetic fields such as electric motors, speakers, and other devices.
- Keep dust from entering the cassette tape compartment. All dust is abrasive and causes excessive wear on the tape and the camcorder's recording and playback heads.
- Never use tapes with damaged or spliced tape.
- Do not use a tape if it has been damaged or exposed to moisture. The tape might jam and/or damage the camcorder.

Other Information

Things to Avoid

- Do not attempt to disassemble the camcorder. There are no user-serviceable parts inside.
- Avoid operating the camcorder immediately after moving it from a cold location to a warm location. Give the camcorder 1-1/2 to 2 hours to reach a stable temperature before inserting a tape.
- In cold to warm conditions, condensation might occur causing the tape to stick to the recording heads and damage the camcorder or tapes.
- Never aim the camcorder at the sun or other bright objects.
- Do not leave the camcorder in direct sunlight for extended periods of time. The resulting heat buildup might permanently damage the camcorder's internal parts or reduce the life of the clock battery.
- Do not operate the camcorder in extremely humid environments.
- Do not operate the camcorder near the ocean as salt water or spray might damage the internal parts of the camcorder.
- Do not operate the camcorder for extended periods in temperatures below 40°F (4°C) or above 95°F (35°C).
- Do not expose the camcorder or power supply/charger to rain or moisture. If any component becomes wet, turn off the power and take the unit to an authorized RCA camcorder service provider.
- Do not use any power supply/charger or batteries other than the ones specified for the camcorder. Using the wrong accessories might cause damage to the camcorder.

Traveling Tips

- Write down your camcorder's serial number and keep it separate from the camcorder when traveling. If your camcorder is lost or stolen, you will be able to identify it.
- Use extra care to avoid damage to your camcorder and accessories when operating them at a beach or pool. Spray, sand, and dust should be avoided. If your lens has been exposed to the elements, clean it only with proper lens cleaning supplies.
- Make sure you have any plug adapters that you might need before taking your camcorder to other countries. Consult your dealer for advice.
- Carry your camcorder in a carrying case when traveling. See the accessories section (*page 96*) for a case designed especially for this camcorder. An ordinary suitcase or carry bag does not offer the protection your camcorder needs. Treat your camcorder as carry-on luggage to protect it from rough handling.

Specifications

Camcorder

Format

DV NTSC standard

Power source

DC 11 V $\overline{\text{---}}$ (Using AC power supply)

DC 7.2 V $\overline{\text{---}}$ (Using battery pack)

Power consumption

Viewfinder on:
4.3 W

LCD monitor on:
5.3 W

Video light: 3.5 W

Signal system

NTSC-type

Recording/Playback Format

Video: digital component recording
Audio: PCM digital recording, 32 kHz
4-channel (12-bit), 48 kHz 2-channel
(16-bit)

Cassette tape

Mini DV cassette tape

Tape speed

SP: 18.8 mm/sec.
LP: 12.5 mm/sec.

Recording time (max.)

SP: 80 minutes

LP: 120 minutes (with 80 min cassette)

Operating temperature

0°C to 40°C (32°F to 104°F)

Operating humidity

35% to 80%

Storage temperature

-20°C to 50°C (-4°F to 122°F)

Weight

Approx. 590 g (1.4 lbs)

Dimensions (W x H x D)

83 mm x 97 mm x 188 mm (3-5/16" x 3-7/8" x 7-7/16") (with the LCD monitor closed and with the viewfinder fully tilted downward)

Pickup

1/4" format CCD

Lens

F1.8, f = 3.6 mm to 36 mm, 10:1 power zoom lens, filter diameter \varnothing 37 mm

Viewfinder

Electronic viewfinder with .24" black and white LCD.

White balance adjustment

Auto/Manual adjustment

LCD monitor system

2.5" diagonally measured, LCD panel/TFT active matrix

Speaker

Monaural

Other Information

Audio/Video Jacks

S-Video

Y: 1 V(p-p), 75 Ω , analog

C: 0.29 V(p-p), 75 Ω , analog

Video

1 V (p-p), 75 Ω analog output (via Video output connector)

Audio

300 mV (rms), 1 k Ω analog stereo output (via Audio output connector)

DV

4-pin, IEEE 1394 compliant

Service Port

\varnothing 3.5 mm, 4-pole

AC Power Supply

Power requirement

U.S.A. and Canada: AC 120 V, 60 Hz

Other countries: AC 110 V to 240 V, 50 Hz/60 Hz

Output

DC 11 V $\overline{\text{---}}$, 1A

Dimensions (W x H x D)

59 mm x 31 mm x 84 mm (2-3/8" x 1-1/4" x 3-5/16")

Weight

Approx. 130 g (0.29 lbs)

RCA Digital Camcorder Limited Warranty

What your warranty covers:

- Defects in materials or workmanship.

For how long after your purchase:

- 90 days from date of purchase for labor charges.
- One year from date of purchase for parts.

The warranty period for rental units begins with the first rental or 45 days from date of shipment to the rental firm, whichever comes first.

What we will do:

During the initial 90 days

Exchange your camcorder with a new or refurbished unit, or repair your camcorder. The option will be ours. There will be no cost to you.

After the 90 days and within one year

Exchange your camcorder with a new or refurbished unit, or repair your camcorder. The option will be ours. Parts will be provided at no charge, but you will be responsible for the cost of labor required for the repair.

How you get service:

- Call 1-800-283-6503 and have your unit's date of purchase and model/serial number ready. The model/serial number information is on the bottom of your camcorder.
- A representative will troubleshoot your problem over the phone. If the representative determines that you should receive a replacement unit, you will be provided with a Service Request (SR) number and the location of a nearby exchange point if one exists. No returns will be accepted without the SR number.
- Proof of purchase in the form of a bill of sale or receipted invoice which is evidence that the product is within the warranty period must be presented to obtain warranty service. For rental firms, proof of first rental is also required.

Other Information

To receive a replacement Camcorder before you return yours:

Option I

1. Provide your Discover, MasterCard, or Visa account number and expiration date to our phone representative. This is for security purposes. If we receive your unit, excluding all accessories, within 14 days from the date you were provided the SR number, only items not covered by warranty will be charged to your account. **IF YOUR UNIT IS NOT RECEIVED WITHIN 14 DAYS, THE SUGGESTED RETAIL VALUE OF THE CAMCORDER WILL BE CHARGED TO YOUR CREDIT CARD.** This amount, less \$10.00 handling, will be credited if the unit is subsequently received.
2. We will send you a replacement unit.
3. Ship the unit back to us, excluding all accessories, using the replacement unit's carton. Shipping instructions will be included in the carton along with your SR number which will allow you to easily ship the unit back to us. **Make sure you insure your shipment in case of damage or loss.** Include with the shipment:
 - Evidence of purchase date, such as a bill of sale to verify your unit's warranty eligibility.
 - A brief note describing your camcorder's problem.
 - Your name, address and phone number.

Return transportation, storage, handling, and insurance costs are your sole responsibility. We accept no liability in case of damage or loss.

Option II

1. For a fee of \$10.00, we will send a replacement unit to the exchange point.
2. The exchange location will notify you of its arrival.
3. Take your unit, excluding all accessories, and your evidence of purchase date, such as a bill of sale, to the exchange location and you will be provided the new or refurbished unit.
4. If the repairs were covered by your warranty, you will not be billed.

To receive a replacement unit after we have received your unit:

- 1. Write the SR number on the outside of the carton used to return the unit. Make sure you insure your shipment in case of damage or loss.**
- Carefully pack the unit, excluding all accessories, using the original box and packing material if possible.
- Include with the shipment:
 - Evidence of purchase date, such as a bill of sale to verify your unit's warranty eligibility.
 - A brief note describing your camcorder's problem.
 - Your name, address and phone number.

Return transportation, storage, handling, and insurance costs are your sole responsibility. We accept no liability in case of damage or loss.

- The representative will advise the address to mail a cashier's check or money order for payment if there are any out of warranty labor or parts charges and you elect not to use your credit card.
- Upon receipt of your product, a new or refurbished unit will be shipped to you.

What your warranty does not cover:

- Adjustment of customer controls.
- Damage from misuse or neglect.
- A unit that has been modified or incorporated into other products or is used for institutional or other commercial purposes.
- Batteries for remote control and clock.
- Cleaning of video/audio heads.
- Camcorders purchased or serviced outside the U.S.A.
- Return transportation, storage and handling costs of your unit, including insurance for loss or damage.
- Acts of nature, such as but not limited to lightning damage.

Other Information

Product Registration:

- Please complete and mail the Product Registration Card packed with your Camcorder. It will make it easier to contact you should it ever be necessary. The return of the card is not required for warranty coverage.

Limitation of Warranty:

- **THE WARRANTY STATED ABOVE IS THE ONLY WARRANTY APPLICABLE TO THIS PRODUCT. ALL OTHER WARRANTIES, EXPRESS OR IMPLIED (INCLUDING ALL IMPLIED WARRANTIES OF MERCHANTABILITY OR FITNESS FOR A PARTICULAR PURPOSE) ARE HEREBY DISCLAIMED. NO VERBAL OR WRITTEN INFORMATION GIVEN BY THOMSON MULTIMEDIA INC., ITS AGENTS OR EMPLOYEES SHALL CREATE A WARRANTY OR IN ANY WAY INCREASE THE SCOPE OF THIS WARRANTY.**
- **REPAIR OR REPLACEMENT AS PROVIDED UNDER THIS WARRANTY IS THE EXCLUSIVE REMEDY OF THE CONSUMER. THOMSON MULTIMEDIA INC. SHALL NOT BE LIABLE FOR INCIDENTAL OR CONSEQUENTIAL DAMAGES RESULTING FROM THE USE OF THIS PRODUCT OR ARISING OUT OF ANY BREACH OF ANY EXPRESS OR IMPLIED WARRANTY ON THIS PRODUCT. THIS DISCLAIMER OF WARRANTIES AND LIMITED WARRANTY ARE GOVERNED BY THE LAWS OF THE STATE OF INDIANA. EXCEPT TO THE EXTENT PROHIBITED BY APPLICABLE LAW, ANY IMPLIED WARRANTY OF MERCHANTABILITY OR FITNESS FOR A PARTICULAR PURPOSE ON THIS PRODUCT IS LIMITED TO THE APPLICABLE WARRANTY PERIOD SET FORTH ABOVE.**

How State Law relates to warranty:

- Some states do not allow the exclusion nor limitation of incidental or consequential damages, or limitations on how long an implied warranty lasts, so the above limitations or exclusions may not apply to you.
- This warranty gives you specific legal rights, and you also may have other rights that vary from state to state.

If you purchased your camcorder outside the United States:

- This warranty does not apply. Contact your dealer for warranty information.

FCC and Industry Canada Information

FCC Regulations state that unauthorized changes or modifications to this equipment may void the user's authority to operate it.

This device complies with part 15 of FCC Rules. Operation is subject to the following two conditions: (1) This device may not cause harmful interference, and (2) This device must accept any interference received, including interference that may cause undesired operation.

This Class B digital apparatus complies with the Canadian ICES-003.

Cet appareil numérique de la Classe B est conforme à la norme NMB-003 du Canada.

This equipment has been type tested and found to comply with the limits for a Class B Digital Device in accordance with the specifications in Part 15 of the FCC rules. These rules are designed to provide reasonable protections against radio and television interference in a residential installation. This equipment generates, uses and can radiate radio frequency energy and, if not installed and used in accordance with the instructions, may cause harmful interference to radio communications. However, there is no guarantee that interference will not occur in a particular installation.

If this equipment does cause interference to radio or television reception (which you can determine by turning the equipment off and on), try to correct the interference by one or more of the following measures:

Reorient or relocate the receiving antenna (that is, the antenna for the radio or television that is "receiving" the interference).

Change the position of the Camcorder with respect to the radio or television equipment that is receiving interference.

Move the Camcorder away from the equipment that is receiving interference.

Plug the Camcorder into a different wall outlet so that the Camcorder and the equipment receiving interference are on different branch circuits.

If these measures do not eliminate the interference, please consult your dealer or an experienced radio/television technician for additional suggestions. Also, the Federal Communications Commission has prepared a helpful booklet, "How To Identify and Resolve Radio/TV Interference Problems." This booklet is available from the U.S. Government Printing Office, Washington D.C. 20402. Please specify stock number 004-000-00345-4 when ordering copies.

Optional Accessories

We invite you to take a look at some great ideas for sparking creativity and adding to the fun of using your camcorder. The following pages have a selection of accessories to help make your memorable moments look and sound even better.

These accessories are designed to make the process of recording and watching your videos more enjoyable.

To order accessories, contact your local Dealer.

If a dealer is not nearby, all accessories are available through toll-free ordering or by using the order form found on page 99.

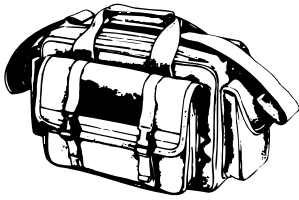

AC201A Soft Carrying Case

Custom compact soft case designed especially to provide protection and utility for your camcorder and most accessories. Rugged fabric lined with soft nonabrasive material and generous padding. Has three outside pockets with storage for lens filters, adapters, batteries, and tapes.

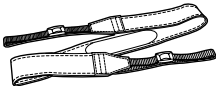

ACS091 Shoulder Strap

Designed to replace the shoulder strap that came with your camcorder.

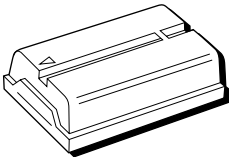

247800 Rechargeable Battery Pack

Replacement battery for the one that came with your camcorder.

All specifications and descriptions of accessories are subject to change without notice.

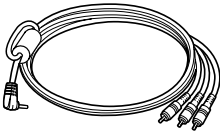

252885 A/V Cable

Replacement for the included A/V cable. Used to attach the camcorder to an external component like a TV or VCR.

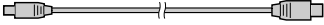

H2011 DV Cable

Used to connect the camcorder to a compatible PC with a IEEE1394 DV interface.

Using the Optional AC088 Tripod

Mounting the camcorder on a tripod, such as AC088, keeps the camcorder steady and produces excellent video results.

This tripod's fluid-effect head provides smooth camera pan and tilt. The quick-release mount makes it easy to attach or remove the camcorder. The grooved, tubular 3-section leg design folds down to 26" when not in use. Rubber feet allow for sure footing.

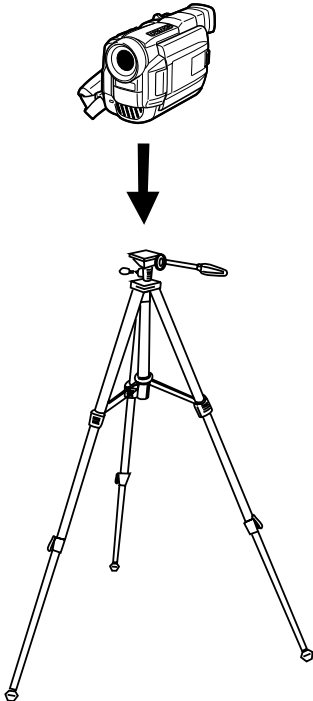

Cautions:

- Before using a tripod, make sure it is stable enough to hold the camcorder without falling over. Do not transport the camcorder attached to the tripod.
- When attaching your camcorder to a tripod, be careful not to force the tripod screw into the camcorder's tripod mounting hole.
- The tripod screw should not protrude into the camcorder more than approximately three-eighths (3/8) of an inch. Forcing the screw could damage the mounting hole on the bottom of the camcorder.

Other Information

To order accessories, contact your local Dealer.

If a dealer is not nearby, you can also follow the directions below to order by telephone or direct-by-mail.

United States and Canada Orders

To place your order by phone, have your Visa, MasterCard, or Discover card ready and call the toll-free number listed below.

Use this number only to place an order for accessory items listed on this order form.

1-800-338-0376

To place your order by mail, detach and mail the completed order form with credit card information, money order, or check in U.S. currency (made payable to Thomson multimedia Inc.) to the following address:

Video Accessories

PO Box 8419

Ronks, PA 17573

Accessories Order Form

Description	Part No.	Price	Qty.	Total
Super Lightweight Tripod	AC088	\$ 49.95		
Soft Camcorder Case	AC201A	\$ 34.95		
Shoulder Strap	ACS091	\$ 12.95		
Rechargeable Battery	247800	\$ 84.95		
Extended Life Battery	BB46L	\$ 69.99		
AC Power Supply	250814	\$ 92.95		
IEEE1394 DV Cable	H2011	\$ 34.95		
A/V Cable	252885	\$ 27.25		

All prices subject to change without notice.

Total Merchandise \$ _____

Sales Tax \$ _____

We are required by law to collect the appropriate sales tax for each individual state, county, and locality to which the merchandise is being sent.

Shipping and Handling \$ **5.00** _____

Total Amount Enclosed \$ _____

Use VISA, MasterCard, or Discover.
Money order or check must be in U.S. currency only. No COD or cash.

Detach Here



Please complete other side also



Other Information

Charge your order on your VISA, MasterCard,
or Discover Card by filling in below

USE YOUR CREDIT CARD

IMPORTANT: Copy complete account number from your VISA card

Expiration date:



IMPORTANT: Copy complete account number from your MasterCard

Expiration date:



IMPORTANT: Copy complete account number from your Discover Card

Expiration date:



AUTHORIZED SIGNATURE

Prices are subject to change without notice.

Print or type your name and
address clearly.



A complete and correct order will
save you days of waiting.

Name: _____
Street: _____
_____ Apt: _____
City: _____
State: _____ Zip: _____

Please make sure that both sides of this form have been filled out completely.

- Allow 4 weeks for delivery.
- All accessories are subject to availability.

Detach Here



This page intentionally left blank.

This page intentionally left blank.

A

- Accessories 96
 - order form 99
- Advanced features 61
- Audio/video input jacks 50
- Auto focus 70
- Automatic recording
 - AutoShot 11

B

- Basic playback 46
- Battery
 - care and storage 18
 - charging 15
 - icon 18
 - life 18
 - removing 16
- Blank search 43
- Buttons and controls 7

C

- Cam reset 76
- Cassettes
 - care and storage 85
 - inserting 12
 - mini DV 12
 - record protection tab 12
- Charging the battery 15
- Choose your connection 50
- Cinema mode 75
- Cleaning 86
- Connecting to a computer 78
- Connecting to a TV (or VCR) with a/v inputs 50
- Connecting to a TV (or VCR) with an S-Video input 51
- Connecting to another DV camcorder 54

D

- Date and time
 - setting 21
- Date/time insert 73
- Digital zooming 35
- Dubbing to a VCR 53
- Dubbing to another digital video camcorder 54
- DV cable 78

E

- Exposure control 68
- Eyepiece focus control 25

F

- Fade/Wipe effects 62
- FCC information 95
- Final notes 83
- Firewire connection 78
- Focus icons 32
- Focusing 70
- Frame-by-frame playback 49

G

- Getting started 9

H

- Handstrap
 - adjusting 9

I

- Icons 26
- IEEE1394 connection 78
- Important information 2
- Industry Canada information 95
- Insert a cassette tape 12
- Iris lock 69

J

Journalistic shooting 34

L

LCD monitor 13, 24

LCD monitor brightness
adjusting 47

Lens cap
attaching 10

Letterbox 75

Light switch 11

Limited warranty 91

M

Manual focus 71

Manual white balance 73

Manual white balance icons 29

Menu definitions 57

MENU/BRIGHT dial 13

Menus 56

Mini DV 12

N

Night mode 61

O

On-screen icons 26

Order form 99

P

Parts checklist 6

Playback

basic 46

fram-by-frame 49

shuttle search 48

still 48

Playback on a TV (or VCR) with A/
V inputs 52

Playback options 46

Plug adapter 19

Power supply 19

attaching 10

removing 19

POWER switch 52

Power zoom lever

volume control 47

Powering the camcorder 11, 15

Product registration 2

Program AE with special effects
65

Program AE with special effects
icons 28

R

Record protection tab 12

Recording

icon 14, 34

playing back 14

tape speed 22

Recording and playback icons 27

Recording tips 44

Removing the battery 16

Removing the power supply 19

Resetting factory defaults 76

S

- S-Video input jack 51
- Seeing what you are recording 24
- Self-recording 35
- Shoulder strap 6, 20
- Shuttle search 48
- Snapshot mode 40
- Speaker volume 47
- Specifications 89
- Squeeze mode 75
- Start recording 14
- Status icons 29
- Steady Pix icon 32
- Steady Pix™ 37
- Still playback 48
- STOP button 52

T

- Tape care and storage 87
- Tape recording speed
 - setting 22
- Tapes
 - Mini DV 12
- Things to avoid 88
- Time code
 - display 39
- Time counter icon 32
- Time-remaining icon 32
- Transferring snapshots and video to
 - a computer 78
- Traveling tips 88
- Troubleshooting 80
- Turning off the camcorder 15

V

- Video light 11, 38
- Video light details 38
- Viewfinder 13, 25
- Volume 47

W

- W and T (zoom lever) 35
- Warning icons 26
- Warranty 91
- White balance adjustment 72
- Wide mode 74
- Wind cut 76

Z

- Zoom lever 30, 35
- Zooming
 - digital 35
 - optical 35
 - zoom lever 35

Please do not send any products to the Indianapolis address listed in this manual or on the carton. This will only add delays in service for your product.

Thomson multimedia Inc.
10330 North Meridian Street
Indianapolis, IN 46290

©2001 Thomson multimedia Inc.
Trademark(s)® Registered
Marca(s) Registrada(s)
Printed in Japan
TOCOM 15781690
Part No. LYT0817-001A(VP)